



ZXA10 C300/C350/C320

Optical Access Convergence Equipment

Hardware Description

Version: V2.1.0

ZTE CORPORATION
No. 55, Hi-tech Road South, ShenZhen, P.R.China
Postcode: 518057
Tel: +86-755-26771900
Fax: +86-755-26770801
URL: <http://support.zte.com.cn>
E-mail: 800@zte.com.cn

LEGAL INFORMATION

Copyright © 2018 ZTE CORPORATION.

The contents of this document are protected by copyright laws and international treaties. Any reproduction or distribution of this document or any portion of this document, in any form by any means, without the prior written consent of ZTE CORPORATION is prohibited. Additionally, the contents of this document are protected by contractual confidentiality obligations.

All company, brand and product names are trade or service marks, or registered trade or service marks, of ZTE CORPORATION or of their respective owners.

This document is provided “as is”, and all express, implied, or statutory warranties, representations or conditions are disclaimed, including without limitation any implied warranty of merchantability, fitness for a particular purpose, title or non-infringement. ZTE CORPORATION and its licensors shall not be liable for damages resulting from the use of or reliance on the information contained herein.

ZTE CORPORATION or its licensors may have current or pending intellectual property rights or applications covering the subject matter of this document. Except as expressly provided in any written license between ZTE CORPORATION and its licensee, the user of this document shall not acquire any license to the subject matter herein.

ZTE CORPORATION reserves the right to upgrade or make technical change to this product without further notice. Users may visit the ZTE technical support website <http://support.zte.com.cn> to inquire for related information.

The ultimate right to interpret this product resides in ZTE CORPORATION.

Revision History

Revision No.	Revision Date	Revision Reason
R1.0	2016-12-31	First edition

Serial Number: SJ-20161220134736-002

Publishing Date: 2016-12-31 (R1.0)

Contents

About This Manual	I
Chapter 1 Cabinets	1-1
1.1 Indoor Cabinets.....	1-2
1.2 Outdoor Cabinets.....	1-4
1.3 Indoor Cabinet Accessories	1-10
Chapter 2 Shelves	2-1
2.1 ZXA10 C300 ETSI 21-Inch Shelf	2-1
2.2 ZXA10 C300 IEC 19-Inch Shelf.....	2-3
2.3 ZXA10 C350 Shelf.....	2-5
2.4 ZXA10 C320 Shelf.....	2-6
Chapter 3 Cards.....	3-1
3.1 Switching and Control Cards.....	3-5
3.2 Ethernet Uplink Cards.....	3-10
3.2.1 10GE Ethernet Uplink Cards	3-10
3.2.2 10GE/GE Ethernet Uplink Cards	3-12
3.2.3 GE Ethernet Uplink Cards.....	3-14
3.3 PON Interface Cards	3-16
3.3.1 EPON Interface Cards	3-16
3.3.2 GPON Interface Cards.....	3-19
3.3.3 10G-EPON Interface Cards.....	3-21
3.3.4 XG-PON1 Interface Card	3-23
3.3.5 GPON/XG-PON1 Interface Card	3-26
3.3.6 XGS-PON Interface Card.....	3-28
3.4 Ethernet Interface Cards.....	3-30
3.5 TDM Interface Cards	3-33
3.5.1 STM-N CES Interface Card.....	3-33
3.5.2 E1/T1 TDM Interface Cards	3-35
3.6 Common Interface Cards.....	3-37
3.7 Power Cards.....	3-39
3.8 Backplanes.....	3-43
3.9 Fan Boxes	3-45
Chapter 4 Cables	4-1
4.1 External Power Cable.....	4-1

4.2 Shelf Power Cable.....	4-2
4.3 E1 Balanced Cable.....	4-3
4.4 E1 Unbalanced Cable.....	4-5
4.5 Serial Port Cable.....	4-7
4.6 Monitoring Cables.....	4-8
4.7 Ethernet Cable.....	4-10
4.8 Fiber Pigtail.....	4-11
Glossary.....	I

About This Manual

Purpose

This manual provides information about the hardware structure of the ZXA10 C300/C350/C320, helping users to learn about the structures and technical specifications of the shelf, cards, fan unit, and cables.

Intended Audience

This manual is intended for debug engineers.

What Is in This Manual

This manual contains the following chapters

Chapter 1, Cabinets	Describes the outline, configuration and technical specifications of the cabinets.
Chapter 2, Shelves	Describes the outline, configuration and technical specifications of the shelves.
Chapter 3, Cards	Describes the functions, operating principles, panels and technical specifications of the cards installed in the ZXA10 C300/C350/C320.
Chapter 4, Cables	Describes cables connected to the ZXA10 C300/C350/C320.

Conventions

This manual uses the following conventions.

	Note: provides additional information about a topic.
---	--

This page intentionally left blank.

Chapter 1

Cabinets

Table 1-1 lists the ZXA10 C300/C350/C320 cabinets.

Table 1-1 ZXA10 C300/C350/C320 Cabinets

Type	Model	Description
Indoor cabinet	B6030-22C-IB	<ul style="list-style-type: none"> • Dimensions: 2200 mm×600 mm×300 mm (Height × Width × Depth) • Configuration shelf: ZXA10 C300/C320 shelfc • Typical configuration: two ZXA10 C300/C320 shelves
	B6030-22C-EB	<ul style="list-style-type: none"> • Dimensions: 2200 mm×600 mm×300 mm (Height × Width × Depth) • Configuration shelf: 21–inch ZXA10 C300 shelf • Typical configuration: two ZXA10 C300 shelves
Outdoor cabinet	EC40EB	<ul style="list-style-type: none"> • Dimensions: 1650mm × 1600 mm × 500mm (Height × Width × Depth) • Configuration shelf: 19–inch ZXA10 C300 shelf/21–inch ZXA10 C300 shelf • Maximum configuration: one ZXA10 C300 shelf.
	EC50EC-S	<ul style="list-style-type: none"> • Dimensions: 1500mm × 850 mm × 500mm (Height × Width × Depth) • Configuration shelf: ZXA10 C350 shelf • Maximum configuration: two ZXA10 C350 shelves.
	EC70E	<ul style="list-style-type: none"> • Dimensions: 1300 mm × 800 mm × 350 mm (Height × Width × Depth) • Configuration shelf: ZXA10 C320 shelf • Maximum configuration: two ZXA10 C320 shelves.
	EC90EB	<ul style="list-style-type: none"> • Dimensions: 1200 mm × 650 mm × 250 mm (Height × Width × Depth) • Configuration shelf: ZXA10 C320 shelf • Maximum configuration: one ZXA10 C320 shelf.

Table of Contents

Indoor Cabinets.....	1-2
Outdoor Cabinets.....	1-4
Indoor Cabinet Accessories.....	1-10

1.1 Indoor Cabinets

B6030-22C-IB cabinet and 6030-22C-EB cabinet have the same appearance. The only difference is the position of installation columns. [Figure 1-1](#) shows the cabinet appearance.

Figure 1-1 Cabinet Appearance



[Figure 1-2](#) shows the cabinet configuration.

Figure 1-2 Cabinet Configuration

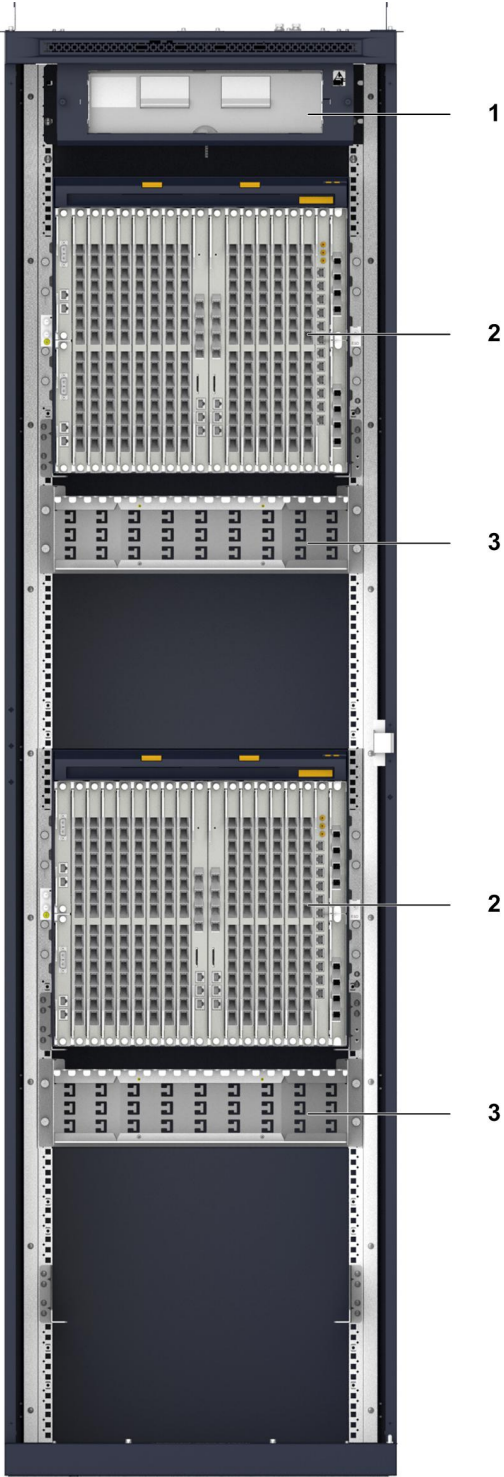

1. PDU

2. ZXA10 C300 shelf

3. Wiring box

1.2 Outdoor Cabinets

EC40EB Cabinet

Figure 1-3 shows the EC40EB cabinet appearance.

Figure 1-3 EC40EB Cabinet Appearance



An EC40EB cabinet supports one ZXA10 C300 shelf. Figure 1-4 shows the typical configuration of an EC40EB cabinet.

Figure 1-4 EC40EB Cabinet Configuration**EC50EC-S Cabinet**

Figure 1-5 shows the EC50EC-S cabinet appearance.

Figure 1-5 EC50EC-S Cabinet Appearance

An EC50EC-S cabinet supports one ZXA10 C350 shelf. Figure [Figure 1-6](#) shows the typical configuration of an EC50EC-S cabinet.

Figure 1-6 EC50EC-S Cabinet Configuration**EC70E Cabinet**

An EC70E cabinet supports two ZXA10 C320 shelves. [Figure 1-7](#) shows the typical configuration of an EC70E cabinet.

Figure 1-7 EC70E Cabinet Configuration**EC90EB Cabinet**

Figure 1-8 shows the EC90EB cabinet appearance.

Figure 1-8 EC90EB Cabinet Appearance

An EC90EB cabinet supports one ZXA10 C320 shelf. [Figure 1-9](#) shows the typical configuration of an EC90EB cabinet.

Figure 1-9 EC90EB Cabinet Configuration

1.3 Indoor Cabinet Accessories

PDU

The [PDU](#) connects two channels of external $-48\text{ V}/-60\text{ V}$ power supply (active/standby) and provides active/standby $-48\text{ V}/-60\text{ V}$ power to power cards of each ZXA10 C300/C320 shelf. The [PDU](#) is installed on the top of the cabinet.

There are two types of [PDUs](#): 19-inch [PDU](#) and 21-inch [PDU](#). The only difference is the width of mounting flanges. [Figure 1-10](#) and [Figure 1-11](#) show the appearances of two types of [PDUs](#) (unit: mm).

Figure 1-10 19-Inch PDU

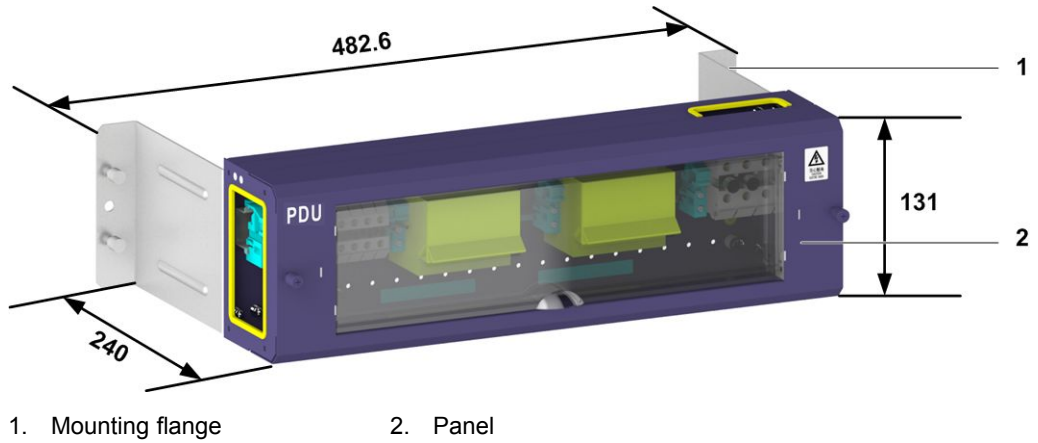
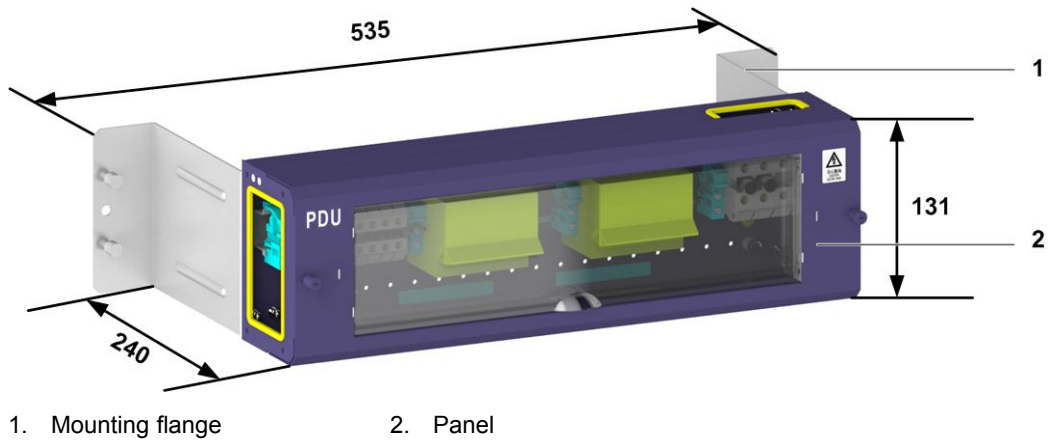

Figure 1-11 21-Inch PDU



Two captive screws fix the cover panel on the PDU. Figure 1-12 shows the PDU structure without the cover panel.

Figure 1-12 PDU Structure

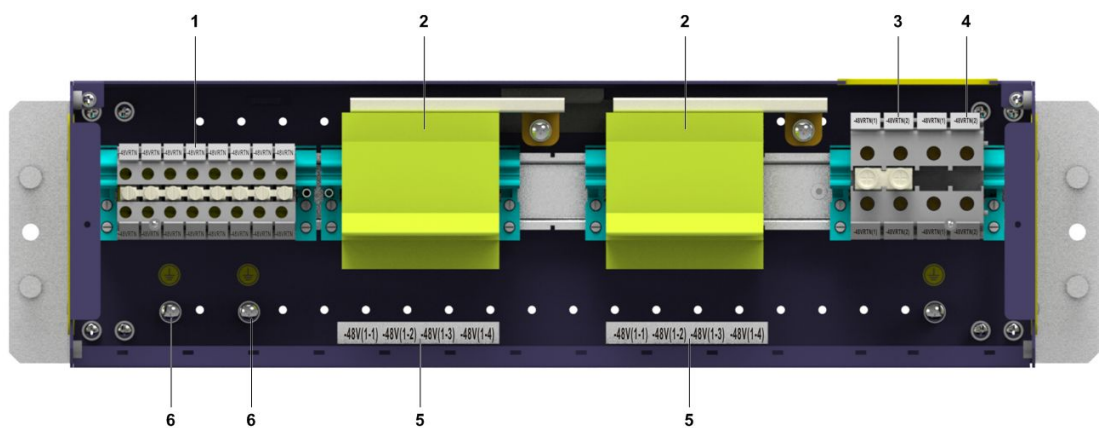

Table 1-2 describes the PDU structure.

Table 1-2 PDU Structure Description

No	Component	Description
1	-48 V/-60 V RTN output	Connects to -48 V/-60 V RTN shelf power cable.
2	Switch	-48 V/-60 V power switch
3	External -48 V/-60 V RTN input	Connects to external -48 V/-60 V RTN power cable.
4	External -48 V/-60 V input	Connects to external -48 V/-60 V power cable.
5	-48 V/-60 V output	Connects to -48 V/-60 V shelf power cable, four channels (from left to right).
6	PE grounding end	Connects to back column, for protective grounding.

Wiring Box

The wiring box is installed under the ZXA10 C300/C320 shelf for cable routing.

Figure 1-13 and Figure 1-14 show the structures of 19-inch wiring box and 21-inch wiring box.

Figure 1-13 19-Inch Wiring Box Structure

Figure 1-14 21-Inch Wiring Box Structure



Adjustable Base

When an equipment room has static conductive floor, to ensure the reliable fixing of a cabinet, the cabinet is installed on an adjustable base that is mounted on the concrete floor. Through the adjustable base, the cabinet bottom and the static conductive floor can be kept on the same level.

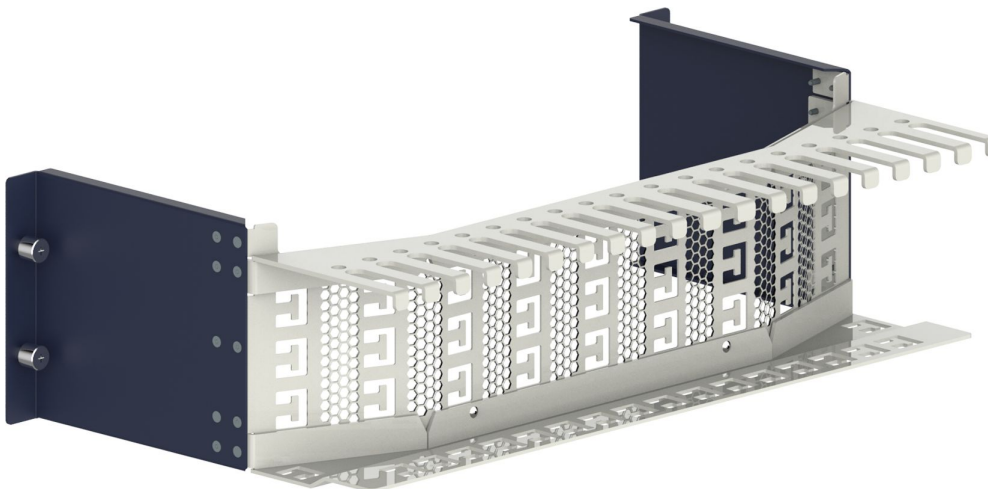
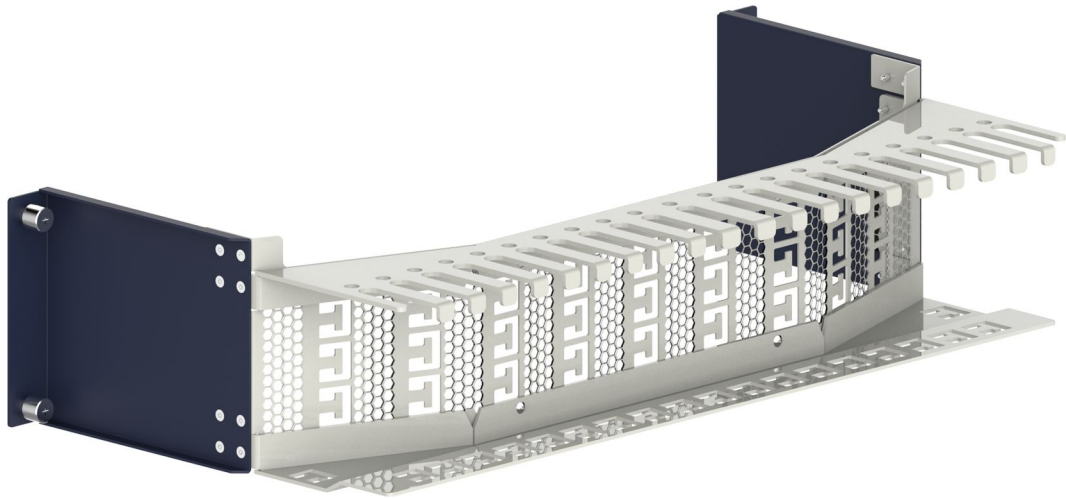
The height of the cabinet base is adjustable. There are three types of cabinet base with different height range:

- 160 mm – 260 mm
- 260 mm – 460 mm
- 460 mm – 660 mm

Figure 1-15 shows the adjustable base structure.

Figure 1-15 Adjustable Base Structure

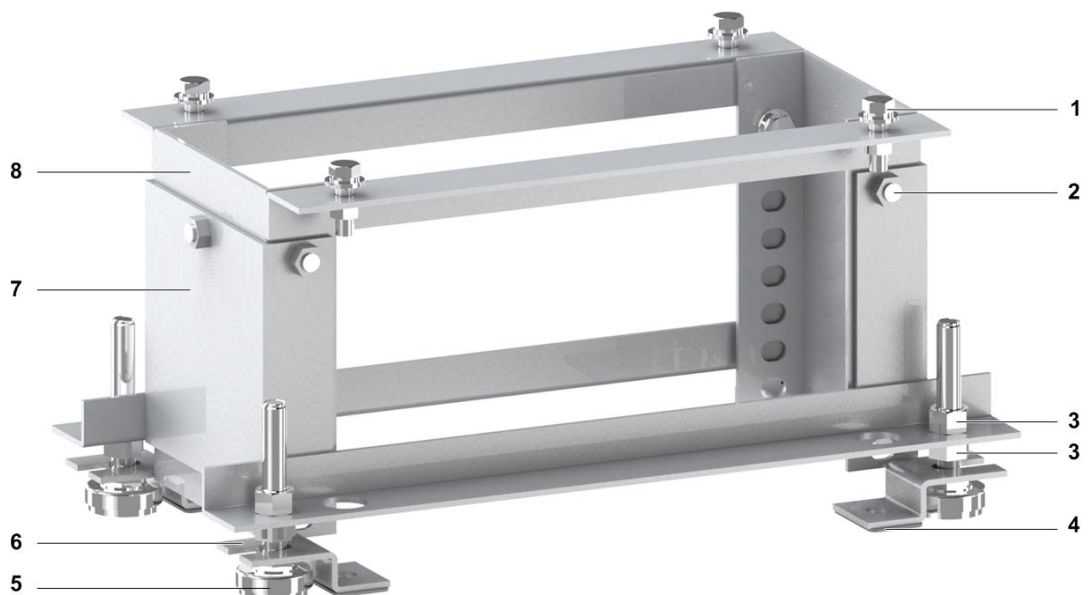

For the description of the adjustable base structure, refer to [Table 1-3](#).

Table 1-3 Adjustable Base Structure Description

No.	Component	Description
1	M12×40 bolt (including gasket and spring washer)	For the cabinet fastening on the base.
2	Height-locking M12×25 bolt	For the movable bracket fastening on the fixed bracket.
3	Adjustable M16 nut	For slight adjustment of base height.
4	Insulation washer	For insulation between the base and concrete floor.
5	Adjustable foot M16×90	For slight adjustment of base height.
6	Fixing plate	For the base fixing.
7	Fixed bracket	Adjust the relative position of the movable bracket and fixed bracket to adjust the base height. The scale on the movable bracket shows the base height.
8	Movable bracket	

Chapter 2

Shelves

Table of Contents

ZXA10 C300 ETSI 21-Inch Shelf	2-1
ZXA10 C300 IEC 19-Inch Shelf	2-3
ZXA10 C350 Shelf.....	2-5
ZXA10 C320 Shelf.....	2-6

2.1 ZXA10 C300 ETSI 21-Inch Shelf

Structure

The ZXA10 C300 21-inch shelf is installed in a B6030-22C-EB cabinet. [Figure 2-1](#) shows the 21-inch shelf structure.

Figure 2-1 ZXA10 C300 21-Inch Shelf Structure



1. Fan section

2. Card section

Configuration

The shelf is divided into two sections: card section and fan section.

- Card section

The 9U-height section is used for switching and control cards and service cards installation.

Figure 2-2 shows the 21-inch shelf configuration.

Figure 2-2 ZXA10 C300 21-Inch Shelf Configuration

Fan																				
0	2	3	4	5	6	7	8	9	10	11	12	13	14	15	16	17	18	19	20	21
Power card	Service card	Service card	Service card	Service card	Service card	Service card	Service card	Service card	Switching and control card	Switching and control card	Service card	Service card	Service card	Service card	Service card	Service card	Service card	Service card	Common interface card	Uplink card
1																				22
Power card																				Uplink card

Width of the Slot 0/1/10/11/21/22 is 25 mm, while width of other slots is 22.5 mm.

Table 2-1 lists the shelf configuration description.

Table 2-1 ZXA10 C300 21-Inch Shelf Configuration Description

Slot Number	Card Type
0/1	Power card
2 to 9	PON interface card, TDM interface card, and Ethernet interface card
10/11	Switching and control card
12 to 19	PON interface card, TDM interface card, and Ethernet interface card
20	Common interface card
21/22	Uplink card

- Fan section

The fan box is 1U in height and 21-inch in width.

It provides the system with cool wind in ventilating way. Fan speed can be adjusted according to the system temperature.

Technical Specifications

Table 2-2 lists technical specifications of the 21-inch shelf.

Table 2-2 Technical Specifications of ZXA10 C300 21-Inch Shelf

Item	Specification
Dimensions	449.2 mm × 535 mm × 270 mm (Height × Width × Depth)
Weight	14 kg (empty) 36.6 kg (full configuration)

2.2 ZXA10 C300 IEC 19-Inch Shelf

Structure

The ZXA10 C300 19-inch shelf is installed in a B6030-22C-IB cabinet. [Figure 2-3](#) shows the 19-inch shelf structure.

Figure 2-3 ZXA10 C300 19-inch Shelf Structure

1. Fan section

2. Card section

Configuration

The shelf is divided into two sections: card section and fan section.

- Card section

The 9U-height section is used for switching and control cards and service cards installation.

Figure 2-4 shows the 19-inch shelf configuration.

Figure 2-4 ZXA10 C300 19-Inch Shelf Configuration

Fan																			
0	2	3	4	5	6	7	8	9	10	11	12	13	14	15	16	17	18	19	
Power card	Service card	Service card	Service card	Service card	Service card	Service card	Service card	Service card	Switching and control card	Switching and control card	Service card	Service card	Service card	Service card	Service card	Service card	Common interface card	Uplink card	
1																		20	Uplink card
Power card																			

Width of the Slot 0/1/10/11/19/20 is 25 mm, while width of other slots is 22.5 mm.

Table 2-3 lists the shelf configuration description.

Table 2-3 ZXA10 C300 19-Inch Shelf Configuration Description

Slot Number	Card Type
0/1	Power card
2 to 9	PON interface card, TDM interface card, and Ethernet interface card
10/11	Switching and control card
12 to 17	PON interface card, TDM interface card, and Ethernet interface card
18	Common interface card
19/20	Uplink card

- Fan section

The fan box is 1U in height and 19-inch in width.

It provides the system with cool wind in ventilating way. Fan speed can be adjusted according to the system temperature.

Technical Specifications

Table 2-4 lists technical specifications of the 19-inch shelf.

Table 2-4 ZXA10 C300 19-Inch Shelf Technical Specifications

Item	Specification
Dimensions	443.7 mm × 482.6 mm × 270 mm (Height × Width × Depth)

Item	Specification
Weight	12.5 kg (empty) 34.2 kg (full configuration)

2.3 ZXA10 C350 Shelf

Appearance

Figure 2-5 shows the appearance of the ZXA10 C350 shelf.

Figure 2-5 Appearance of the ZXA10 C350 Shelf



Configuration

Figure 2-6 shows the ZXA10 C350 shelf configuration.

Figure 2-6 ZXA10 C350 Shelf Configuration

Fan box	0	Uplink card	1	Uplink card
	2	Interface card		
	3	Interface card		
	4	Interface card		
	5	Interface card		
	6	Switching and control card		
	7	Switching and control card		
	8	Interface card		
	9	Interface card		
	10	Interface card		
	11	Power card	12	Power card

For a description of the shelf configuration, refer to [Table 2-5](#).

Table 2-5 ZXA10 C350 Shelf Configuration Description

Slot	Card
0/1	Uplink card
2 to 5, 8 to 9	PON interface card/P2P interface card
6/7	Switching and control card
10	Common interface card/PON interface card/P2P interface card
11/12	Power card (for mutual power assistance)

Technical Specifications

For the technical specifications of the ZXA10 C350 shelf, refer to [Table 2-6](#).

Table 2-6 ZXA10 C350 Shelf Technical Specifications

Item	Specification
Dimensions	263.9 mm × 482.6 mm × 240 mm (Height × Width × Depth)
Weight	8 kg (without cards) 18 kg (full configuration)

2.4 ZXA10 C320 Shelf

Appearance

The ZXA10 C320 shelf is a 19-inch shelf of 2U in height. [Figure 2-7](#) shows the appearance of the ZXA10 C320 shelf.

Figure 2-7 ZXA10 C320 Shelf Appearance



Configurations

Figure 2-8 shows the configurations of the shelf.

Figure 2-8 ZXA10 C320 Shelf Configuration

Fan	PON interface card/P2P interface card		1
	PON interface card/P2P interface card		2
	Switching and control card	3	Switching and control card



Note:

When the ZXA10 C320 uses AC power supply, the AC power card PRAM is installed in slot 3.

Technical Specifications

Table 2-7 lists the technical specifications of the ZXA10 C320 shelf.

Table 2-7 ZXA10 C320 Shelf Technical Specifications

Item	Specification
Dimensions	86.1 mm × 482.6 mm × 270 mm (height × width × depth)
Weight	2.5 kg (empty) 6.9 kg (full configuration)

This page intentionally left blank.

Chapter 3

Cards

Table 3-1 lists the cards supported by the ZXA10 C300/C350/C320.

Table 3-1 Card List

Card Type	Name	Description	Function
Switching and control card	SCXN	Type-N switching and control card	<ul style="list-style-type: none"> ● ZXA10 C300/C350 switching and control card ● 1 out-of-band NM interface ● 1 serial interfac ● 1 SD card interface ● 4 GE uplink interfaces
	SCTM	Type-T switching and control card	<ul style="list-style-type: none"> ● ZXA10 C300/C350 switching and control card ● 1 out-of-band NM interface ● 1 serial interface ● 1 SD card interface ● 4 10GE uplink interfaces ● 1 mirroring interface
	SCXM	Type-M switching and control card	<ul style="list-style-type: none"> ● ZXA10 C300/C350 switching and control card ● 1 out-of-band NM interface ● 1 serial interfac ● 1 SD card interface
	SCXL	Type-L switching and control card	<ul style="list-style-type: none"> ● ZXA10 C300/C350 switching and control card ● 1 out-of-band NM interface ● 1 serial interfac ● 1 SD card interface
	SMXA	Type-L switching and control card	<ul style="list-style-type: none"> ● ZXA10 C320 switching and control card ● 1 out-of-band NM interface ● 1 serial interfac ● 1 monitor interface ● 1 GE uplink electrical interface ● The GE optical interface is available when a UCDC/1 daughter card is installed. The GE optical interface can

Card Type	Name	Description	Function
			be modified to a 10GE optical interface with a UCDC/3 daughter-card is installed. 1 GE optical interface and 1 10GE optical interface are available when a UCDC/5 daughter card is installed.
Clock daughter card	CKWSA	Clock daughter card	Clock daughter card for SCXN
Ethernet uplink card	XUTQ	4-port 10GE optical interface Ethernet uplink card	4 10GE optical interfaces
	XUVQ	4-port 10GE optical interface Ethernet uplink card	4 10GE optical interfaces Supports SynE and IEEE 1588
	HUTQ	2-port 10GE and 2-port GE optical interface Ethernet uplink card	2 10GE and 2 GE optical interfaces
	HUVQ	2-port 10GE and 2-port GE optical interface Ethernet uplink card	<ul style="list-style-type: none"> 2 10GE and 2 GE optical interfaces Supports SynE and IEEE 1588
	GUFQ	4-port GE optical interface Ethernet uplink card	4 GE optical interfaces
	GUSQ	2-port GE optical and 2-port GE electrical interface Ethernet uplink card	2 GE/FE optical and 2 GE electrical interfaces
Uplink daughter card	UCDC/1	2-port GE uplink daughter card for SMXA	2 GE optical interfaces
	UCDC/3	1-port 10GE and 1-port GE uplink daughter card for SMXA	1 GE and 1 10GE optical interfaces
	UCDC/5	1-port 10GE and 1-port GE uplink daughter card for SMXA	<ul style="list-style-type: none"> 2 GE optical interfaces supports SynE and 1588v2

Card Type	Name	Description	Function
PON interface card	GTGO	8-port GPON interface card	8 GPON interfaces
	GTGH	16-port GPON interface card	16 GPON interfaces
	GTXO	8-port XG-PON1 interface card	8 XG-PON1 interfaces
	GTBO	8-port GPON/XG-PON1 interface card	8 GPON/XG-PON1 interfaces
	GTTO	8-port XGS-PON interface card	8 XGS-PON interfaces
	ETGO	8-port EPON interface card	8 EPON interfaces
	ETGH	16-port EPON interface card	16 EPON interfaces
	ETXD	2-port asymmetric 10G-EPON interface card	2 10G-EPON interfaces
	ETTO	8-port symmetric/asymmetric 10G-EPON interface card	8 10G-EPON interfaces
Ethernet interface card	FTGK	48-port P2P Ethernet interface card	48 GE/FE optical interfaces
	GDFO	8-port GE optical Ethernet interface card	8 GE/FE optical interfaces
TDM interface card	CTLA	STM-N TDM interface card	2 STM-1 or 1 STM-4 interface
	CTBB	32-channel E1 balanced TDM interface card	32 E1 balanced interfaces
	CTUB	32-channel E1 unbalanced TDM interface card	32 E1 unbalanced interfaces
	CTTB	32-channel T1 balanced TDM interface card	32 T1 balanced interfaces

Card Type	Name	Description	Function
Common interface card	CICG	Common interface card, supports clock processing, environment monitoring, and OAM.	<ul style="list-style-type: none"> ● 2 BITS/1PPS+TOD clock input interface ● 1 BITS/1PPS+TOD clock output interface
	CICK	Common interface card, supports clock/time processing, environment monitoring, and OAM.	<ul style="list-style-type: none"> ● 1 out-of-band NM interface ● 1 pulic serial port ● 1 temperature sensor interface ● 1 humid sensor interface ● 1 smog sensor interface ● 1 liquid sensor interface ● 1 entrance control sensor interface ● 1 digit input interface ● 1 digit output interface
Power card	PRWG	4.5U power interface card	<ul style="list-style-type: none"> ● ZXA10 C300/C350 power card ● 1 power interface ● 2 RJ-45 interfaces (reserved)
	PRWH	4.5U power interface card	
	PRAM	AC power card	<ul style="list-style-type: none"> ● ZXA10 C320 AC power card ● 1 AC power interface ● 1 battery interface ● 1 temperature sensor interface
Fan control card	FCWB	Fan control card	<ul style="list-style-type: none"> ● ZXA10 C300 fan control card ● Supports single line fan box
	FCWD		<ul style="list-style-type: none"> ● ZXA10 C300 fan control card ● Supports dual line fan box
	FCWR		ZXA10 C350 fan control card
	F2U		ZXA10 C320 fan control card
Backplane	MWIA/R	ZX10 C300 19-inch backplane	ZXA10 C300 10U 19-inch backplane
	MWIA		
	MWEA/R	ZX10 C300 21-inch backplane	ZXA10 C300 10U 21-inch backplane
	MWEA		
	MWRV	6U 19-inch backplane	ZXA10 C350 6U 19-inch backplane
	MWMT	2U 19-inch backplane	ZXA10 C320 2U 19-inch backplane

Table of Contents

Switching and Control Cards3-5

Ethernet Uplink Cards3-10

PON Interface Cards3-16

Ethernet Interface Cards3-30

TDM Interface Cards3-33

Common Interface Cards3-37
 Power Cards3-39
 Backplanes3-43
 Fan Boxes.....3-45

3.1 Switching and Control Cards

Function

The switching and control cards are responsible for system control and management, implement the non-blocking switching for all service cards in the ZXA10 C300/C350/C320.

The ZXA10 C300/C350/C320 supports the following switching and control cards:

- SCTM: supports 2.56 Tbps switching capacity, 256k MAC address table.
- SCXN: supports 480 Gbps switching capacity, 32k MAC address table, and VoIP function (with VoIP daughter-card).
- SCXM: supports 480 Gbps switching capacity and 32k MAC address table.
- SCXL: supports 800 Gbps switching capacity and 32k MAC address table.
- SMXA: supports 128 Gbps switching capacity, 32k MAC address table.

Panel

Figure 3-1, Figure 3-2, Figure 3-3, Figure 3-4 and Figure 3-5 show the switching and control card panels.

Figure 3-1 SCTM Panel



Figure 3-2 SCXN Panel



Figure 3-3 SCXM Panel



Figure 3-4 SCXL Panel



Figure 3-5 SMXA Panel

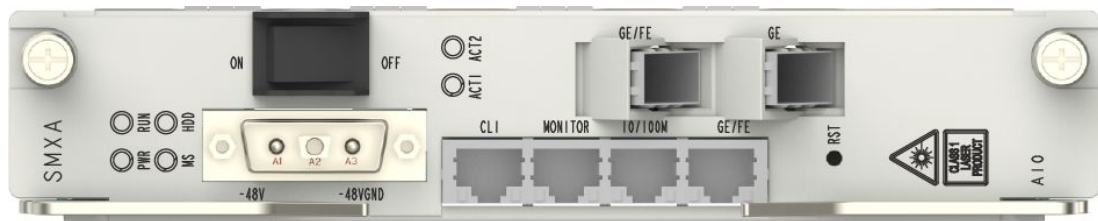

Indicators

Table 3-2 describes the indicators of the switching and control cards.

Table 3-2 Indicator Description for Switching and Control Cards

Indicator	Status	Description
RUN	OFF	The card is not powered ON.
	Green LED flashes slowly (1 Hz).	The card works properly (INSERVICE).
	Green LED flashes quickly (2 Hz).	<ul style="list-style-type: none"> The card is in configuration process. The card is in BOOT writing process. Do Not pull out the card.
	Green LED is ON.	<ul style="list-style-type: none"> The card is in version starting process. The card is in BOOTROM program. The card is in PLD upgrading process.
	Red LED is ON.	The card is seriously faulty, such as hardware fault.
	Yellow LED flashes slowly (1 Hz).	The card type is inconsistent with configuration (TYPEMISMATCH).
M/S	Green LED is ON.	This card is the active.
	LED is OFF.	This card is the standby.
HDD	OFF	Reserved, not available in current version.
ACT i (i = 1 – 4)	OFF	The link is down.
	Green LED is ON.	The link is up, but no data transmission.
	Green LED flashes.	The interface is transmitting and receiving data.
PWR	LED is OFF.	The power is off.
	Green LED is ON.	The power supply from the panel is proper.
	Red LED is ON.	The power supply from the panel is faulty.

Interfaces

Table 3-3 describes the interfaces of the switching and control cards.

Table 3-3 Interface Description for Switching and Control Cards

Interface	Description
GE1–GE4	GE optical interface, for uplink
GE/FE (electrical)	GE electrical interface, for uplink
GE/FE (optical)	GE optical interface, for uplink
XGE1–XGE4	10GE optical interface, for uplink
SD	SD card socket, for importing/exporting data
CLI	RS-232 port, for local commissioning
10/100M	RJ45 interface, for out-of-band network management
DIAG	RJ45 interface, for mirroring service traffic
MONITOR	Environment monitoring interface
–48 V/–48 V GND	–48 V power socket

**Note:**

For the SMXA card, the GE optical interface is available when a UCDC/1 daughter card is installed. The GE optical interface can be modified to a 10GE optical interface with a UCDC/3 daughter-card is installed. 1 GE optical interface and 1 10GE optical interface are available when a UCDC/5 daughter card is installed.

Button

Table 3-4 describes the buttons on the switching and control cards.

Table 3-4 SMXA Buttons Description

Button	Description
ON/OFF	To enable/disable the power supply of the equipment
RST	To reset the card

Principle Diagram

Figure 3-6 and Figure 3-7 show the principle diagrams of the switching and control cards.

Figure 3-6 Principle Diagram of SCXN and SCTM

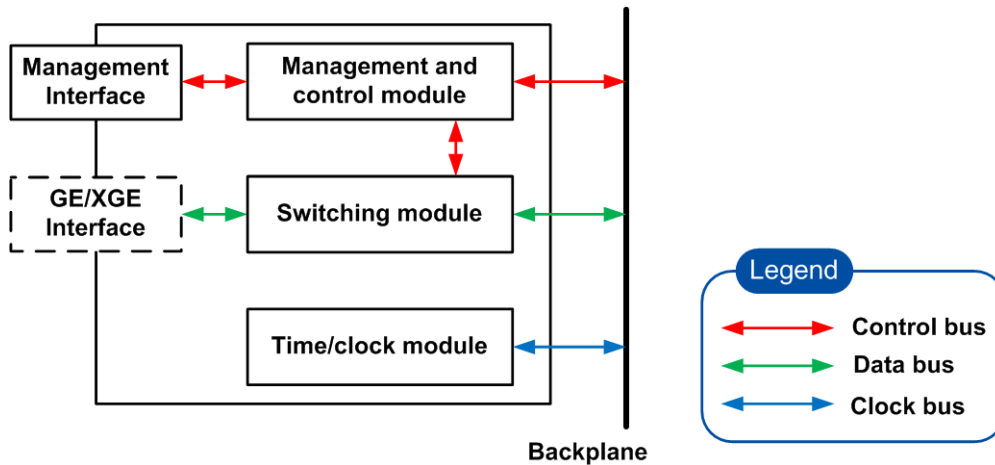

Figure 3-7 Principle Diagram of SMXA

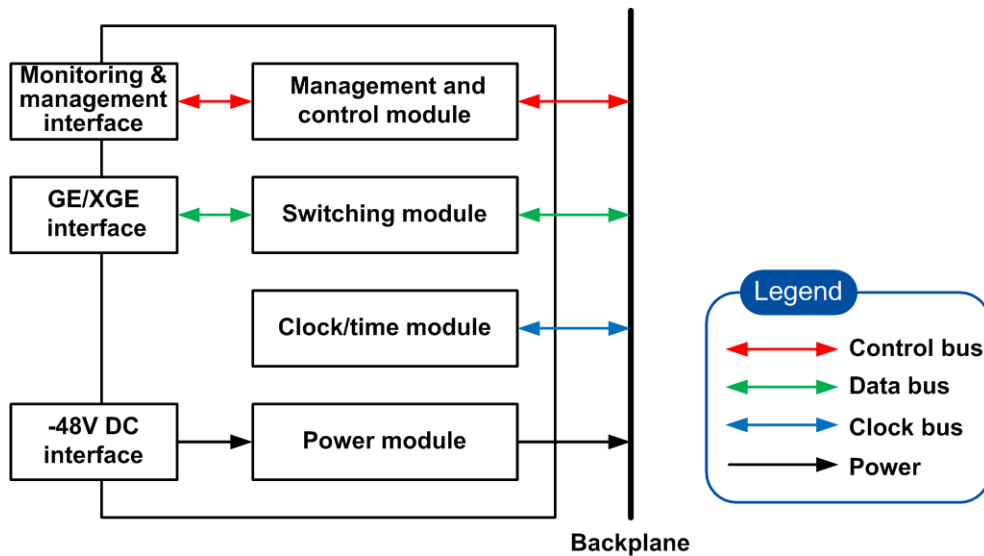

Table 3-5 describes the module functions of the switching and control cards.

Table 3-5 Module Functions of Switching and Control Cards

Module	Function
Switching module	The switching center of data service, implements data switching, Ethernet, VLAN, multicast, IP route, QoS, and security functions.
Management and control module	Consists of control software, protocol processing software, overhead processing, Ethernet switching chip, and control CPU, provides interfaces for cards to forcibly download versions and reset hardware/software, provides online detection for cards, implements fan detection and control functions.
Clock/time module	Processes system clock and time, complies with ITU-T G.8262, G.8264, G.781, and RFC 1305.

Module	Function
Power module	Provides input interface for DC power, provides power protection, monitoring, filtering functions, including lightning-proof, power filtering, and prevention of overload/underload .

Technical Specifications

Table 3-6 lists technical specifications of the switching and control cards.

Table 3-6 Switching and Control Cards Technical Specifications

Item		Specification
Power consumption	SCXN	65 W (static), 80 W (maximum), 75 W (typical)
	SCTM	90 W (static), 120 W (maximum), 110 W (typical)
	SCXM	50 W (static), 70 W (maximum), 60 W (typical)
	SCXL	60 W (static), 90 W (maximum), 75 W (typical)
	SMXA+UCDC/1	20 W (static), 27 W (maximum), 23 W (typical)
	SMXA+UCDC/3	22 W (static), 30 W (maximum), 27 W (typical)
	SMXA+UCDC/5	27 W (static), 36 W (maximum), 32 W (typical)
Dimensions	SCXN	395.5 mm × 25 mm × 225 mm (Height × Width × Depth)
	SCTM	
	SCXM	
	SCXL	
	SMXA	200.25 mm × 37 mm × 225 mm (Height × Width × Depth)
Weight	SCXN	1.145 kg
	SCTM	1.420 kg
	SCXM	1.132 kg
	SCXL	1.141 kg
	SMXA+UCDC/1	0.982 kg
	SMXA+UCDC/3	0.993 kg
	SMXA+UCDC/5	1.031 kg

- Static power consumption: the system is powered on and all user ports are deactivated.
- Maximum power consumption: the system is powered on and all user ports are activated.
- Typical power consumption: the system is powered on and 50% user ports are activated.

3.2 Ethernet Uplink Cards

3.2.1 10GE Ethernet Uplink Cards

Function

The ZXA10 C300/350 supports the following 10GE Ethernet uplink cards:

- XUTQ: 4-port 10GE optical interface Ethernet uplink card
- XUVQ: 4-port 10GE optical interface Ethernet uplink card, supports SynE and IEEE 1588 TC function.

Panel

Figure 3-8 and Figure 3-9 show the 10GE Ethernet uplink card panels.

Figure 3-8 XUTQ Panel



Figure 3-9 XUVQ Panel



Indicators

Table 3-7 describes the indicators for the 10GE Ethernet uplink cards.

Table 3-7 Indicator Description for 10GE Ethernet Uplink Cards

Indicator	Status	Description
RUN	OFF	The card is not powered ON.
	Green LED flashes slowly (1 Hz).	The card works properly (INSERVICE).
	Green LED flashes quickly (2 Hz).	<ul style="list-style-type: none"> ● The card is in configuration process. ● The card is in BOOT writing process. Do Not pull out the card.
	Green LED is ON.	<ul style="list-style-type: none"> ● The card is in version starting process. ● The card is in BOOTROM program. ● The card is in PLD upgrading process.
	Red LED is ON.	The card is seriously faulty, such as hardware fault.

Indicator	Status	Description
	Yellow LED flashes slowly (1 Hz).	The card type is inconsistent with configuration (YPEMISMATCH).
ACT _i (i = 1 – 4)	OFF	The link is down.
	Green LED is ON.	The link is up, but no data transmission.
	Green LED flashes.	The interface is transmitting and receiving data.

Interfaces

The 10GE Ethernet uplink card provides four 10GE Ethernet interfaces.

Principle Diagram

Figure 3-10 shows the principle diagram of the 10GE Ethernet uplink cards.

Figure 3-10 Principle Diagram of 10GE Ethernet Uplink Cards

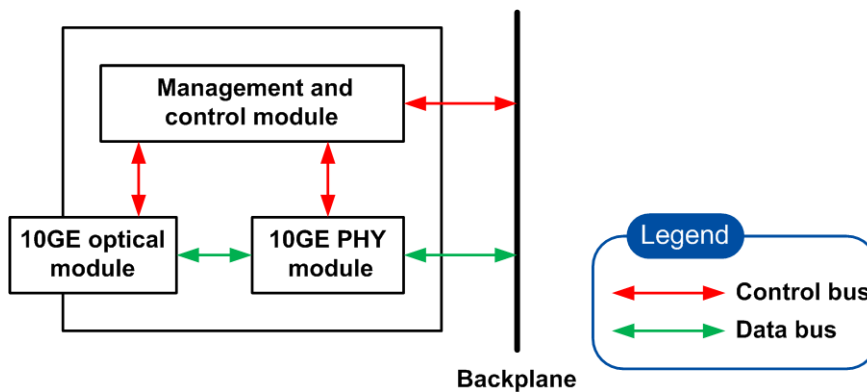

Table 3-8 describes the module functions of the 10GE Ethernet uplink cards.

Table 3-8 Module Function of 10GE Ethernet Uplink Cards

Module	Function
Management and control module	Implements card configuration, traffic management and optical module management, and status detection of optical module.
10GE PHY module	Implements signal connection for switching chip interface and serial Ethernet interface, coding in physical layer, clock recovery and frequency doubling. Implement time input and Ethernet frequency synchronization (only available for XUVQ).
10GE optical module	Provides 10GE optical interface.

Technical Specifications

Table 3-9 lists technical specifications of the 10GE Ethernet uplink cards.

Table 3-9 Technical Specifications of 10GE Ethernet Uplink Cards

Item		Specification
Power consumption	XUTQ	20 W (static), 22 W (maximums), 20 W (typical)
	XUVQ	23 W (static), 25 W (maximums), 23 W (typical)
Dimensions		197.75 mm × 25 mm × 225 mm (Height × Width × Depth)
Weight	XUTQ	0.514 kg
	XUVQ	0.535 kg

3.2.2 10GE/GE Ethernet Uplink Cards

Function

The ZXA10 C300/C350 supports the following 10GE/GE Ethernet uplink cards:

- HUTQ: 2-port 10GE and 2-port GE optical interface Ethernet uplink card
- HUVQ: 2-port 10GE and 2-port GE optical interface Ethernet uplink card, supports SynE and IEEE 1588 TC function.

Panel

Figure 3-11 and Figure 3-12 show the 10GE/GE Ethernet uplink card panels.

Figure 3-11 HUTQ Panel



Figure 3-12 HUVQ Panel



Indicators

Table 3-10 describes the indicators of the 10GE/GE Ethernet uplink cards.

Table 3-10 Indicator Description for 10GE/GE Ethernet Uplink Cards

Indicator	Status	Description
RUN	OFF	The card is not powered ON.
	Green LED flashes slowly (1 Hz).	The card works properly (INSERVICE).
	Green LED flashes quickly (2 Hz).	<ul style="list-style-type: none"> The card is in configuration process. The card is in BOOT writing process. Do Not pull out the card.
	Green LED is ON.	<ul style="list-style-type: none"> The card is in version starting process. The card is in BOOTROM program. The card is in PLD upgrading process.
	Red LED is ON.	The card is seriously faulty, such as hardware fault.
	Yellow LED flashes slowly (1 Hz).	The card type is inconsistent with configuration (TYPEMISMATCH).
XG1/XG2/GE 1/GE2	OFF	The link is down.
	Green LED is ON.	The link is up, but no data transmission.
	Green LED flashes.	The interface is transmitting and receiving data.

Interfaces

The 10GE/GE Ethernet uplink cards provide two 10GE optical interfaces and two GE optical interfaces.

Principle Diagram

Figure 3-13 shows the principle diagram of the 10GE/GE Ethernet uplink cards.

Figure 3-13 Principle Diagram of 10GE/GE Ethernet Uplink Cards

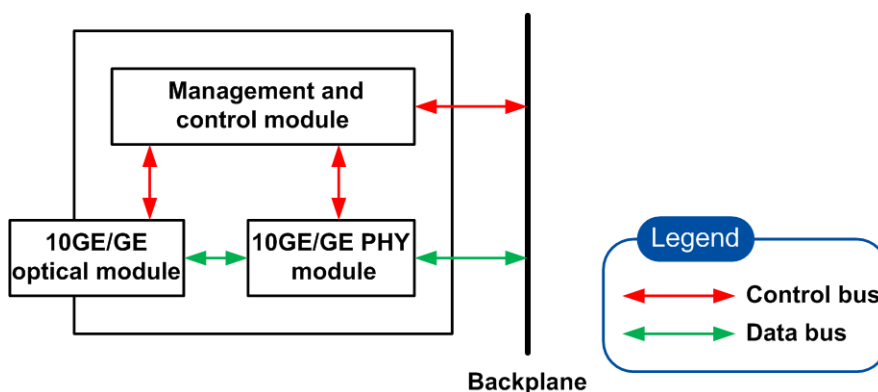

Table 3-11 describes the module functions of the 10GE/GE Ethernet uplink cards.

Table 3-11 Module Function of 10GE/GE Ethernet Uplink Cards

Module	Function
Management and control module	Implements card configuration, traffic management and optical module management, and status detection of optical module.
10GE PHY module/GE PHY module	Implements signal connection for switching chip interface and serial Ethernet interface, coding in physical layer, clock recovery and frequency doubling. Implement time input and Ethernet frequency synchronization (only available for HUVQ).
10GE optical module/GE optical module	Provides 10GE/GE optical interface.

Technical Specifications

Table 3-12 lists technical specifications of the 10GE/GE Ethernet uplink cards.

Table 3-12 Technical Specifications of 10GE/GE Ethernet Uplink Cards

Item	Specification
Power consumption	13 W (static), 15 W (maximums), 13 W (typical)
Dimensions	197.75 mm × 25 mm × 225 mm (Height × Width × Depth)
Weight	HUTQ: 0.420 kg HUVQ: 0.432 kg

3.2.3 GE Ethernet Uplink Cards

Function

The ZXA10 C300/C350 supports the following GE Ethernet uplink cards:

- GUFQ: 4-port optical interface Ethernet uplink card
Four optical interfaces can be GE optical interface (a GFSQ daughter-card needs to be configured), or FE optical interface (an FFSQ daughter-card needs to be configured).
- GUSQ: 2-port optical and 2-port electrical interface Ethernet uplink card
 - Two optical interfaces can be GE optical interface (with a GFSD daughter-card), or FE optical interface (with an FFSD daughter-card).
 - Two electrical interfaces are 10 M/100 M/1000 M adaptive electrical interfaces (with a GTSD daughter-card).

Panel

Figure 3-14 and Figure 3-15 show the GE Ethernet uplink card panels.

Figure 3-14 GUFQ Panel



Figure 3-15 GUSQ Panel



Indicators

Table 3-13 describes the indicators of the GE Ethernet uplink cards.

Table 3-13 Indicator Description for GE Ethernet Uplink Card

Indicator	Status	Description
RUN	OFF	The card is not powered ON.
	Green LED flashes slowly (1 Hz).	The card works properly (INSERVICE).
	Green LED flashes quickly (2 Hz).	<ul style="list-style-type: none"> The card is in configuration process. The card is in BOOT writing process. Do Not pull out the card.
	Green LED is ON.	<ul style="list-style-type: none"> The card is in version starting process. The card is in BOOTROM program. The card is in PLD upgrading process.
	Red LED is ON.	The card is seriously faulty, such as hardware fault.
	Yellow LED flashes slowly (1 Hz).	The card type is inconsistent with configuration (YPEMISMATCH).
ACT i (i = 1 – 4)	OFF	The link is down.
	Green LED is ON.	The link is up, but no data transmission.
	Green LED flashes.	The interface is transmitting and receiving data.

Interfaces

The GE Ethernet uplink cards provide four GE/FE interfaces.

Principle Diagram

Figure 3-16 shows the principle diagram of the GE Ethernet uplink cards.

Figure 3-16 Principle Diagram of GE Ethernet Uplink Card

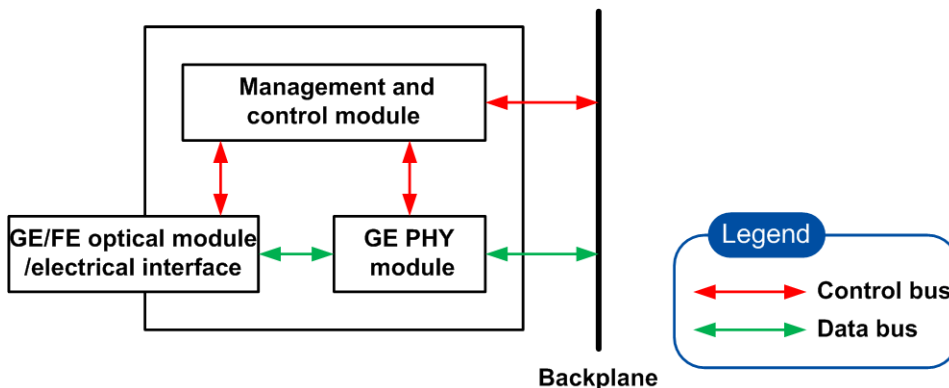

Table 3-14 describes the module functions of the GE Ethernet uplink cards.

Table 3-14 Module Function of GE Ethernet Uplink Cards

Module	Function
Management and control module	Implements card configuration, traffic management and optical module management, and status detection of optical module.
GE PHY module	Implements GE serial Ethernet interface conversion, coding in physical layer, clock recovery and frequency doubling.
GE/FE optical module/electrical interface	Provides GE/FE optical/electrical interface.

Technical Specifications

Table 3-15 lists technical specifications of the GE Ethernet uplink cards.

Table 3-15 Technical Specifications of GE Ethernet Uplink Card

Item	Specification
Power consumption	4 W (static/maximum), 5 W (typical)
Dimensions	197.75 mm × 25 mm × 225 mm (Height × Width × Depth)
Weight	GUFQ: 0.506 kg GUSQ: 0.466 kg

3.3 PON Interface Cards

3.3.1 EPON Interface Cards

Function

The EPON interface cards provide EPON access. The ZXA10 C300/C350/C320 supports the following EPON interface cards:

- ETGH: 16-port EPON interface card
- ETGO: 8-port EPON interface card

Panel

Figure 3-17 and Figure 3-18 show the EPON interface card panels.

Figure 3-17 ETGH Panel



Figure 3-18 ETGO Panel



Indicators

Table 3-16 describes the indicators of the EPON interface cards.

Table 3-16 EPON Interface Cards Indicator Description

Indicator	Status	Description
RUN	OFF	The card is not powered ON.
	Green LED flashes slowly (1 Hz).	The card works properly (INSERVICE).
	Green LED flashes quickly (2 Hz).	<ul style="list-style-type: none"> ● The card is in configuration process. ● The card is in BOOT writing process. Do Not pull out the card.
	Green LED is ON.	<ul style="list-style-type: none"> ● The card is in version starting process. ● The card is in BOOTROM program. ● The card is in PLD upgrading process.
	Red LED is ON.	The card is seriously faulty, such as hardware fault.
	Yellow LED flashes slowly (1 Hz).	The card type is inconsistent with configuration (TYPEMISMATCH).
ACT <i>i</i> /LED <i>i</i> (<i>i</i> =1 – 16)	OFF	The PON interface has no configuration.
	Green LED flashes.	The PON interface is receiving and transmitting data.
	Red LED is ON.	The PON interface has alarm.

Interfaces

The EPON interface cards provide 16/8 EPON optical interfaces.

Button

The RST button is used for resetting card.

Principle

Figure 3-19 shows the principle diagram of the EPON interface cards.

Figure 3-19 EPON Interface Cards Principle Diagram

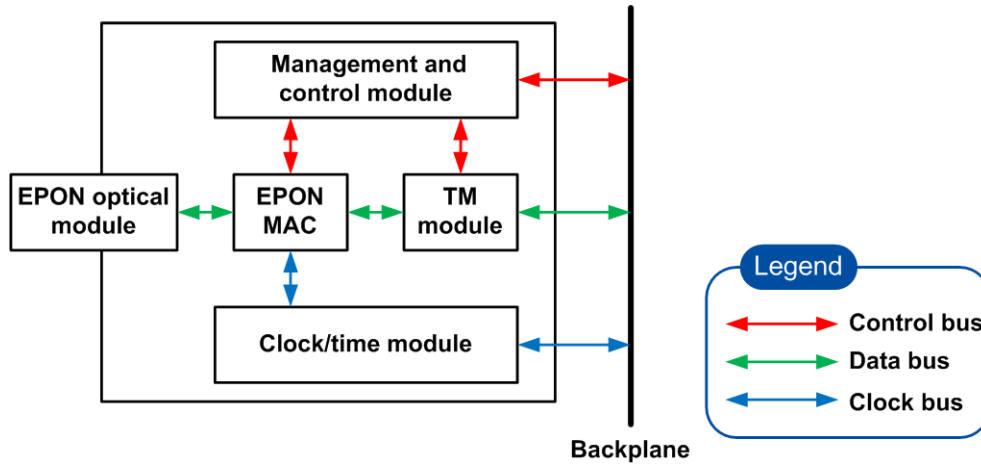

Table 3-17 describes the module functions of EPON interface cards.

Table 3-17 EPON Interface Cards Module Functions

Module	Function
Management and control module	Manages and controls the card, implement card configuration.
EPON MAC module	Implement the EPON functions.
TM module	Processes data in service layer, including bandwidth management and QoS process, satisfies the SLA requirement.
EPON optical module	Provides EPON optical interface, complies with IEEE 802.3.
Clock module	Process system clock, complies with ITU-T G.8262, G.8264, and G.781.

Technical Specifications

Table 3-18 lists technical specifications of the EPON interface cards.

Table 3-18 Technical Specifications of EPON Interface Cards

Item	Specification
Power consumption	ETGH: 5 W (static), 55 W (maximum), 50 W (typical) GTGO: 5 W (static), 33 W (maximum), 27 W (typical)
Dimensions	395.5 mm × 22.5 mm × 225 mm (Height × Width × Depth)
Weight	ETGH: 1.250 kg ETGO: 1.017 kg

3.3.2 GPON Interface Cards

Function

The **GPON** interface cards provide **GPON** access. The ZXA10 C300/C350/C320 supports the following **GPON** interface cards:

- GTGH: 16-port **GPON** interface card
- GTGO: 8-port **GPON** interface card

Panel

Figure 3-20 and Figure 3-21 show the **GPON** interface card panels.

Figure 3-20 GTGH Panel



Figure 3-21 GTGO Panel



Indicators

Table 3-19 describes the indicators of the **GPON** interface cards.

Table 3-19 Indicator Description for **GPON** Interface Cards

Indicator	Status	Description
RUN	OFF	The card is not powered ON.
	Green LED flashes slowly (1 Hz).	The card works properly (INSERVICE).
	Green LED flashes quickly (2 Hz).	<ul style="list-style-type: none"> ● The card is in configuration process. ● The card is in BOOT writing process. Do Not pull out the card.
	Green LED is ON.	<ul style="list-style-type: none"> ● The card is in version starting process. ● The card is in BOOTROM program. ● The card is in PLD upgrading process.
	Red LED is ON.	The card is seriously faulty, such as hardware fault.
	Yellow LED flashes slowly (1 Hz).	The card type is inconsistent with configuration (TYPE MISMATCH).

Indicator	Status	Description
ACT <i>i</i> (i = 1–16)	OFF	The PON interface has no configuration.
	Green LED flashes.	The PON interface has no configuration and discovers new ONU.
	Green LED is ON	ONUs are registered on the PON port and work properly.
	Red LED is ON.	The GPON interface has LOS alarms.

Interfaces

GPON interface cards provide 16/8 GPON interfaces.

Button

The RST button is used for resetting card.

Principle Diagram

Figure 3-22 shows the principle diagram of the GPON interface cards.

Figure 3-22 Principle Diagram of GPON Interface Cards

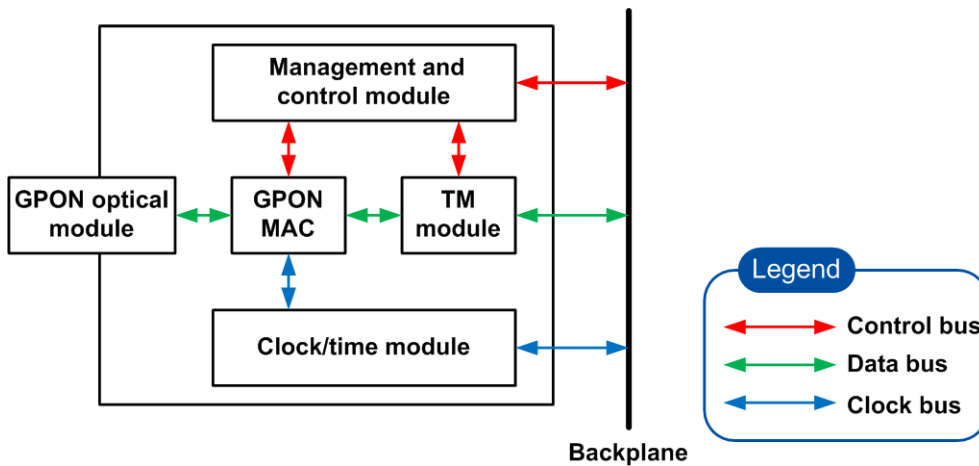

Table 3-20 describes the module functions of GPON interface cards.

Table 3-20 Module Functions of GPON Interface Cards

Module	Function
Management and control module	Manages and controls the card, implement card configuration.
GPON MAC module	Implement the GPON functions defined by ITU-T G.984.3.
TM module	Processes data in service layer, including bandwidth management and QoS process, satisfies the SLA requirement. The process function is compatible with TR156.

Module	Function
GPON optical module	Provides PON-C optical interface, complies with ITU-T G.984.2.
Clock/time module	Process system clock, complies with ITU-T G.8262, G.8264, and G.781.

Technical Specifications

Table 3-21 lists technical specifications of the GPON interface cards.

Table 3-21 Technical Specifications of GPON Interface Cards

Item	Specification
Power consumption	GTGH: 5 W (static), 55 W (maximum), 50 W (typical) GTGO: 5 W (static), 35 W (maximum), 30 W (typical)
Dimensions	395.5 mm × 22.5 mm × 225 mm (Height × Width × Depth)
Weight	GTGH: 1.360 kg GTGO: 0.980 kg

3.3.3 10G-EPON Interface Cards

Function

The 10G-EPON interface cards provide 10G-EPON access. The ZXA10 C300/C350/C320 supports the following 10G-EPON interface cards:

- ETTO: 8-port symmetric/asymmetric 10G-EPON interface card
- ETXD: 2-port asymmetric 10G-EPON interface card

Panel

Figure 3-23 and Figure 3-24 show the 10G-EPON interface card panels.

Figure 3-23 ETTO Panel



Figure 3-24 ETXD Panel



Indicators

Table 3-22 describes the indicators of the 10G-EPON interface cards.

Table 3-22 Indicator Description for 10G-EPON Interface Cards

Indicator	Color	Description
RUN	OFF	The card is not powered ON.
	Green LED flashes slowly (1 Hz).	The card works properly (INSERVICE).
	Green LED flashes quickly (2 Hz).	<ul style="list-style-type: none"> The card is in configuration process. The card is in BOOT writing process. Do Not pull out the card.
	Green LED is ON.	<ul style="list-style-type: none"> The card is in version starting process. The card is in BOOTROM program. The card is in PLD upgrading process.
	Red LED is ON.	The card is seriously faulty, such as hardware fault.
	Yellow LED flashes slowly (1 Hz).	The card type is inconsistent with configuration (YPEMISMATCH).
ACT _i (i=1 – 8)	OFF	The PON interface has no configuration.
	Green LED flashes.	The PON interface is receiving and transmitting data.
	Red LED is ON.	The PON interface has alarm.

Interfaces

The 10G-EPON interface card provides 2/8 10G-EPON optical interfaces.

Button

The RST button is used for resetting card.

Principle

Figure 3-25 shows the principle diagram of the 10G-EPON interface cards.

Figure 3-25 ETTQ/ETXD Principle Diagram

Table 3-23 describes the module functions of 10G-EPON interface cards.

Table 3-23 Module Functions of 10G-EPON Interface Cards

Module	Function
Management and control module	Manages and controls the card, implement card configuration.
10G-EPON MAC module	Implement the PON functions.
TM module	Processes data in service layer, including bandwidth management and QoS process, satisfies the SLA requirements.
10G-EPON optical module	Provides 10G-EPON optical interface, complies with IEEE 802.3av.
Clock module	Processes system clock, complies with ITU-T G.8262, G.8264, and G.781.

Technical Specifications

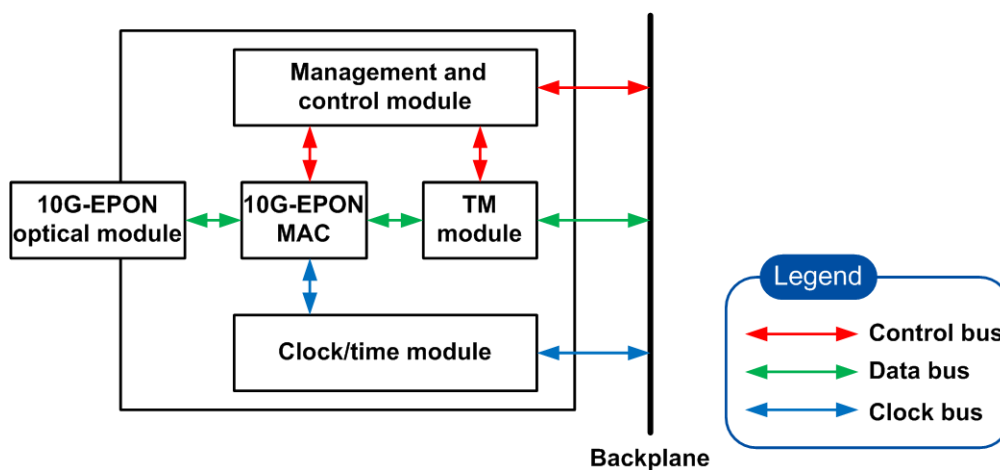
Table 3-24 lists technical specifications of the 10G-EPON interface cards.

Table 3-24 Technical Specifications of 10G-EPON Interface Cards

Item	Specification
Power consumption	ETTO: 5 W (static), 79 W (maximum), 69 W (typical) ETXD: 5 W (static), 60 W (maximum), 50 W (typical)
Dimensions	395.5 mm × 22.5 mm × 225 mm (height × width × depth)
Weight	ETTO: 1.195 kg ETXD: 1.255 kg

3.3.4 XG-PON1 Interface Card

Function

The ZXA10 C300/C350/C320 supports the 8-port XG-PON1 interface card GTXO. GTXO provides XG-PON access.

Panel

Figure 3-26 shows the GTXO panel.

Figure 3-26 GTXO Panel



Indicators

Table 3-25 describes the indicators of the GTXO card.

Table 3-25 Indicator Description for GTXO Card

Indicator	Status	Description
RUN	OFF	The card is not powered ON.
	Green LED flashes slowly (1 Hz).	The card works properly (INSERVICE).
	Green LED flashes quickly (2 Hz).	<ul style="list-style-type: none"> ● The card is in configuration process. ● The card is in BOOT writing process. Do Not pull out the card.
	Green LED is ON.	<ul style="list-style-type: none"> ● The card is in version starting process. ● The card is in BOOTROM program. ● The card is in PLD upgrading process.
	Red LED is ON.	The card is seriously faulty, such as hardware fault.
	Yellow LED flashes slowly (1 Hz).	The card type is inconsistent with configuration (YPEMISMATCH).
ACT _i (i = 1–8)	OFF	The PON interface has no configuration.
	Green LED flashes.	The PON interface has no configuration and discovers new ONU.
	Green LED is ON	ONUs are registered on the PON port and work properly.
	Red LED is ON.	The PON interface has LOS alarms.

Interfaces

The GTXO card provides 8 XG-PON1 interfaces.

Button

The RST button is used for resetting card.

Principle Diagram

Figure 3-27 shows the principle diagram of the GTXO card.

Figure 3-27 Principle Diagram of GTXO Card

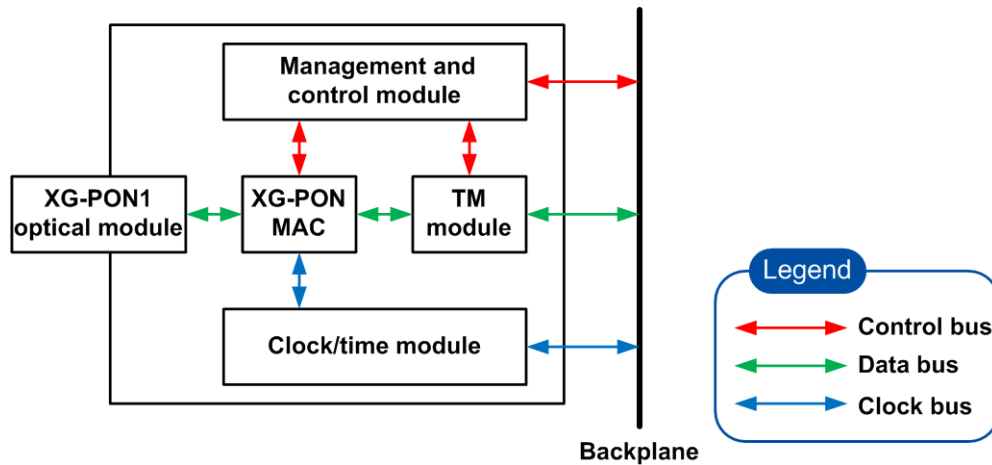

Table 3-26 describes the module functions of the GTXO card.

Table 3-26 Module Functions of GTXO Card

Module	Function
Management and control module	Manages and controls the card, implement card configuration.
XG-PON1 MAC module	Implement the XG-PON1 functions defined by ITU-T G.987.3.
TM module	Processes data in service layer, including bandwidth management and QoS process, satisfies the SLA requirement. The process function is compatible with TR156.
XG-PON1 optical module	Provides XG-PON1 optical interface, complies with ITU-T G.984.2.
Clock/time module	Process system clock, complies with ITU-T G.8262, G.8264, and G.781.

Technical Specifications

Table 3-27 lists technical specifications of the GTXO card.

Table 3-27 Technical Specifications of GTXO Card

Item	Specification
Power consumption	5 W (static), 75 W (maximum), 65 W (typical)
Dimensions	395.5 mm × 22.5 mm × 225 mm (Height × Width × Depth)
Weight	1.185 kg

3.3.5 GPON/XG-PON1 Interface Card

Function

The ZXA10 C300/C350/C320 supports the 8-port asymmetric GPON/XG-PON1 interface card GTBO. GTBO provides GPON/XG-PON1 access.

- GPON access: the downstream rate is 9.953 Gbit/s , and the upstream rate is 2.488 Gbit/s.
- XG-PON1 access: the downstream rate is 2.488 Gbit/s , and the upstream rate is 1.244 Gbit/s.

Panel

Figure 3-28 shows the GTBO panel.

Figure 3-28 GTBO Panel



Indicators

Table 3-28 describes the indicators of the GTBO card.

Table 3-28 Indicator Description for GTBO Card

Indicator	Status	Description
RUN	OFF	The card is not powered ON.
	Green LED flashes slowly (1 Hz).	The card works properly (INSERVICE).
	Green LED flashes quickly (2 Hz).	<ul style="list-style-type: none"> ● The card is in configuration process. ● The card is in BOOT writing process. Do Not pull out the card.
	Green LED is ON.	<ul style="list-style-type: none"> ● The card is in version starting process. ● The card is in BOOTROM program. ● The card is in PLD upgrading process.
	Red LED is ON.	The card is seriously faulty, such as hardware fault.
	Yellow LED flashes slowly (1 Hz).	The card type is inconsistent with configuration (TYPEMISMATCH).
ACT _i (i = 1–8)	OFF	The PON interface has no configuration.
	Green LED flashes.	The PON interface has no configuration and discovers new ONU.
	Green LED is ON	ONUs are registered on the PON port and work properly.
	Red LED is ON.	The PON interface has LOS alarms.

Interfaces

The GTBO card provides 8 GPON/XG-PON1 interfaces.

Button

The RST button is used for resetting card.

Principle Diagram

Figure 3-29 shows the principle diagram of the GTXO card.

Figure 3-29 Principle Diagram of GTBO Card

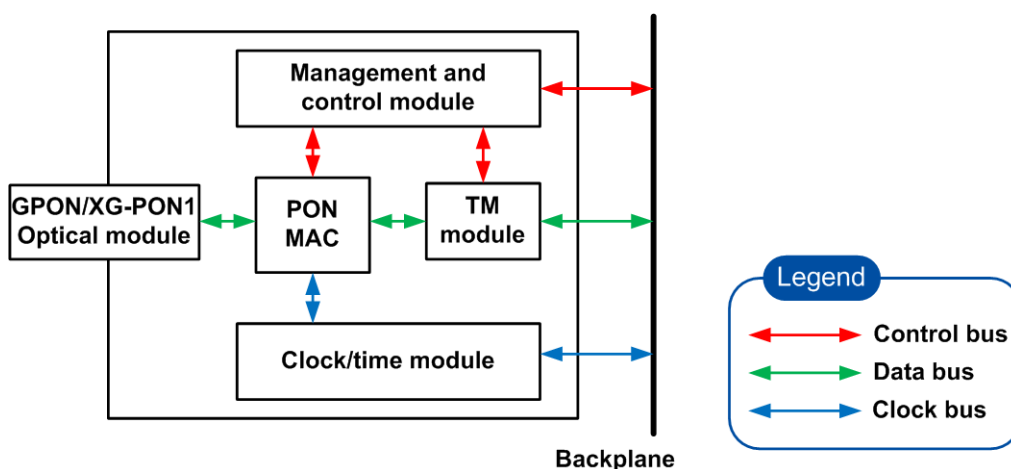

Table 3-29 describes the module functions of the GTBO card.

Table 3-29 Module Functions of GTBO Card

Module	Function
Management and control module	Manages and controls the card, implement card configuration.
PON MAC	Implement the GPON/XG-PON1 functions defined by ITU-T G.987.3.
TM module	Processes data in service layer, including bandwidth management and QoS process, satisfies the SLA requirement. The process function is compatible with TR156.
GPON/XG-PON1 optical module	Provides GPON/XG-PON1 optical interface. GPON complies with ITU-T G.984.2, and XG-PON1 complies with ITU-T G.987.2.
Clock/time module	Process system clock, complies with ITU-T G.8262, G.8264, and G.781.

Technical Specifications

Table 3-30 lists technical specifications of the GTBO card.

Table 3-30 Technical Specifications of GTBO Card

Item	Specification
Power consumption	5 W (static), 80 W (maximum), 70 W (typical)
Dimensions	395.5 mm × 22.5 mm × 225 mm (Height × Width × Depth)
Weight	1.200 kg

3.3.6 XGS-PON Interface Card

Function

The XGS-PON interface card GTTO provides 8-port 10G-GPON access, supposes clock synchronization and 1PPS transparent transmission. The downstream rate is 9.953 Gbit/s, and the upstream burst rate is 9.953 Gbit/s.

Panel

Figure 3-30 shows the XGS-PON interface card panel.

Figure 3-30 GTTO Panel



Indicators

Table 3-31 describes the indicators of the XGS-PON interface card.

Table 3-31 Indicator Description for XGS-PON Interface Card

Indicator	Status	Description
RUN	OFF	The card is not powered ON.
	Green LED flashes slowly (1 Hz).	The card works properly (INSERVICE).
	Green LED flashes quickly (2 Hz).	<ul style="list-style-type: none"> The card is in configuration process. The card is in BOOT writing process. Do Not pull out the card.
	Green LED is ON.	<ul style="list-style-type: none"> The card is in version starting process. The card is in BOOTROM program. The card is in PLD upgrading process.
	Red LED is ON.	The card is seriously faulty, such as hardware fault.
	Yellow LED flashes slowly (1 Hz).	The card type is inconsistent with configuration (YPEMISMATCH).

Indicator	Status	Description
ACT _i (i = 1–8)	OFF	The PON interface has no configuration.
	Green LED flashes.	The PON interface has no configuration and discovers new ONU.
	Green LED is ON	ONUs are registered on the PON port and work properly.
	Red LED is ON.	The XGS-PON interface has LOS alarms.

Interfaces

XGS-PON interface card provides 8 XGS-PON interfaces.

Button

The RST button is used for resetting card.

Principle Diagram

Figure 3-31 shows the principle diagram of the XGS-PON interface card.

Figure 3-31 Principle Diagram of XGS-PON Interface Card

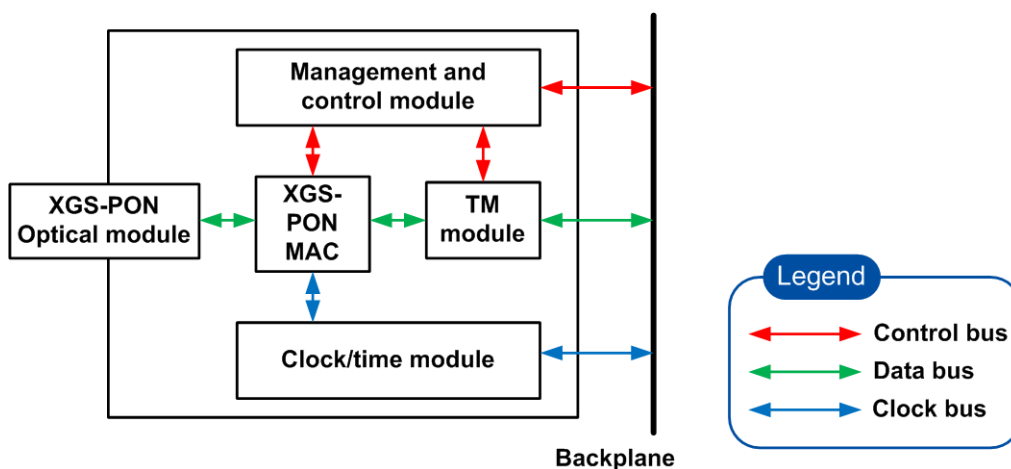

Table 3-32 describes the module functions of XGS-PON interface card.

Table 3-32 Module Functions of XGS-PON Interface Card

Module	Function
Management and control module	Manages and controls the card, implement card configuration.
XGS-PON MAC module	Implement the XGS-PON functions defined by ITU-T G.9807.
TM module	Processes data in service layer, including bandwidth management and QoS process, satisfies the SLA requirement. The process function is compatible with TR156.

Module	Function
XGS-PON optical module	Provides XGS-PON optical interface, complies with ITU-T G.9807.
Clock/time module	Process system clock, complies with ITU-T G.8262, G.8264, and G.781.

Technical Specifications

Table 3-33 lists technical specifications of the XGS-PON interface card.

Table 3-33 Technical Specifications of XGS-PON Interface Card

Item	Specification
Power consumption	5 W (static), 78 W (maximum), 68 W (typical)
Dimensions	395.5 mm × 22.5 mm × 225 mm (Height × Width × Depth)
Weight	1.195 kg

3.4 Ethernet Interface Cards

Function

The ZXA10 C300 supports the following Ethernet interface cards, and ZXA10 C350/C320 only supports the P2P card.

- GDFO: 8-port Ethernet interface card, supports the link aggregation within a card or among cards based on LACP.
- FTGK: 48-port P2P Ethernet interface card, uses WDM technology and single optical fiber for transmitting and receiving.

Panel

Figure 3-32 and Figure 3-33 show the Ethernet interface card panels.

Figure 3-32 GDFO Panel



Figure 3-33 FTGK Panel

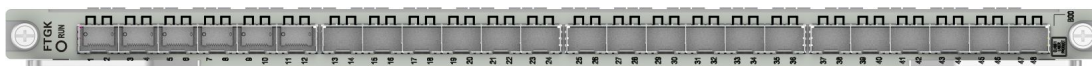

Indicators

Table 3-34 describes the indicators of the Ethernet interface card.

Table 3-34 Indicator Description for Ethernet Interface Cards

Indicator	Status	Description
RUN	OFF	The card is not powered ON.
	Green LED flashes slowly (1 Hz).	The card works properly (INSERVICE).
	Green LED flashes quickly (2 Hz).	<ul style="list-style-type: none"> ● The card is in configuration process. ● The card is in BOOT writing process. Do Not pull out the card.
	Green LED is ON.	<ul style="list-style-type: none"> ● The card is in version starting process. ● The card is in BOOTROM program. ● The card is in PLD upgrading process.
	Red LED is ON.	The card is seriously faulty, such as hardware fault.
	Yellow LED flashes slowly (1 Hz).	The card type is inconsistent with configuration (TYPMISMATCH).
ACT _i /LED _i (i = 1 – 48)	OFF	The link is down.
	Green LED is ON.	The link is up.
	Green LED flashes.	The interface is transmitting and receiving the data.

Interfaces

The GDFO card provides 8 GE optical interfaces (1 – 8).

The FTGK card provides 48 FE/GE optical interfaces (24 ports, each port provides 2 interfaces).

Button

The RST button is used for resetting card.

Principle Diagram

Figure 3-34 shows the principle diagram of the Ethernet interface cards.

Figure 3-34 Principle Diagram of Ethernet Interface Cards

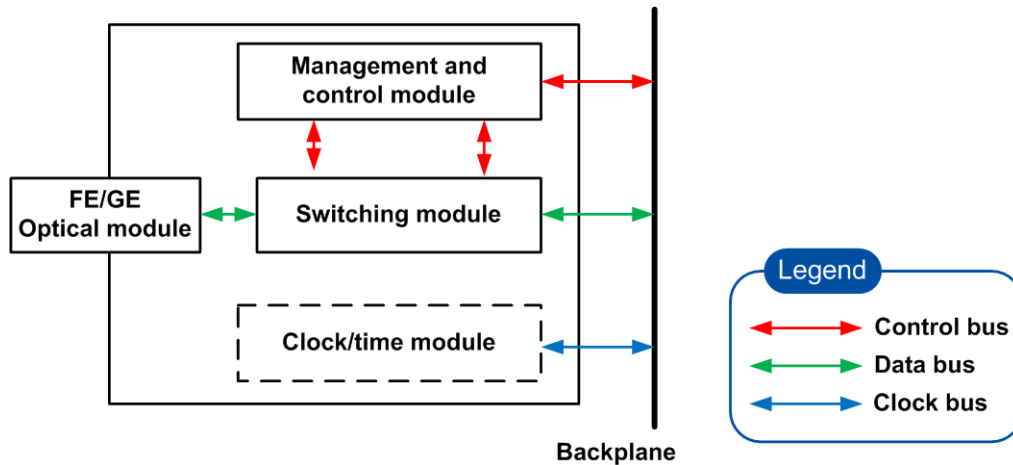

Table 3-35 describes the module functions of the Ethernet interface cards.

Table 3-35 Module Functions of Ethernet Interface Cards

Module	Function
Management and control module	Implements card configuration, traffic management and optical module management, and status detection of optical module.
Switching module	Implements data conversion for optical module and backplane bus, implement VLAN and Ethernet functions.
GE/FE optical module	Provides GE/FE optical interface.
Clock/time module	Process system clock, complies with ITU-T G.8262, G.8264, and G.781. (only for FTGK card)

Technical Specifications

Table 3-36 lists technical specifications of the Ethernet interface cards.

Table 3-36 Technical Specifications of Ethernet Interface Cards

Item	Specification
Power consumption	GDFO: 5 W (static), 30 W (maximum), 27 W (typical) FTGK: 5 W (static), 80 W (maximum), 70 W (typical)
Dimensions	395.5 mm × 22.5 mm × 225 mm (Height × Width × Depth)
Weight	GDFO: 0.755 kg FTGK: 1.560 kg

3.5 TDM Interface Cards

3.5.1 STM-N CES Interface Card

Function

The CTLA card is the [STM-N TDM](#) interface card, it supports [CES](#).

Panel

[Figure 3-35](#) shows the CTLA panel.

Figure 3-35 CTLA Panel



Indicators

[Table 3-37](#) lists the indicator descriptions for the CTLA card.

Table 3-37 CTLA Indicator Description

Indicator	Status	Description
RUN	OFF	The card is not powered ON.
	Green LED flashes slowly (1 Hz).	The card works properly (INSERVICE).
	Green LED flashes quickly (2 Hz).	<ul style="list-style-type: none"> The card is in configuration process. The card is in BOOT writing process. Do Not pull out the card.
	Green LED is ON.	<ul style="list-style-type: none"> The card is in version starting process. The card is in BOOTROM program. The card is in PLD upgrading process.
	Red LED is ON.	The card is seriously faulty, such as hardware fault.
	Yellow LED flashes slowly (1 Hz).	The card type is inconsistent with configuration (TPEMISMATCH).
MOD	OFF	The card is in STM-1 interface (155 M) status.
	Green LED is ON.	The card is in STM-4 interface (622 M) status.
TX/RX	Two green LEDs are ON.	Optical module is ON. Data transmission and receiving is normal.
	Two green LEDs are OFF.	Optical module is OFF without being configured.
	RX Red LED is ON.	LOS or LOF alarm, or multiplex section alarm.
	TX Red LED is ON.	The remote end is invalid.

Interfaces

The CTLA card provides two STM-1 interfaces or one STM-4 interface.

Button

The **RST** button is used for resetting card.

Principle Diagram

Figure 3-36 shows the principle diagram of the CTLA card.

Figure 3-36 CTLA Principle Diagram

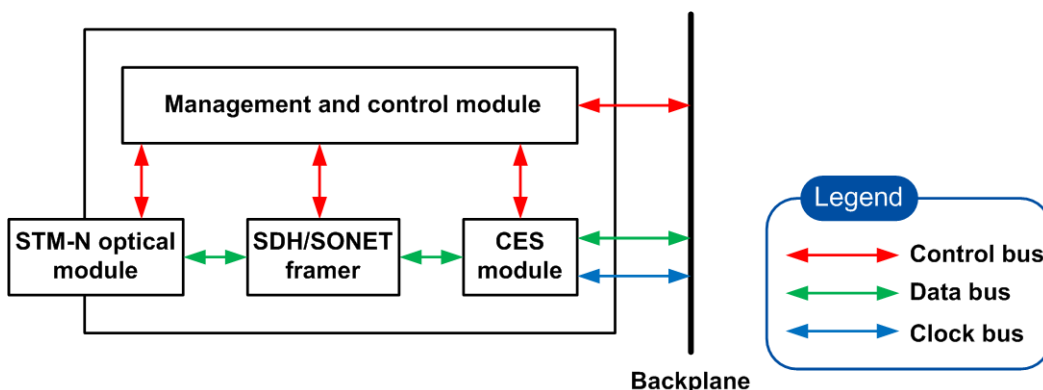

Table 3-38 describes the module functions of the CTLA card.

Table 3-38 CTLA Module Functions

Module	Function
Management and control module	Implements configuration, control, and management for each module in the card.
CES processing module	Encapsulates TDM service data to Ethernet packets and decapsulates Ethernet packets to TDM service data, extracts and restores line clock.
SDH/SONET framer	Processes overheads and alarms of the SDH/SONET optical line.
STM-N optical module	Provides STM-1/STM-4 optical interface.

Technical Specifications

Table 3-39 lists technical specifications of the CTLA card.

Table 3-39 CTLA Technical Specifications

Item	Specification
Power consumption	33 W (static/maximum), 35 W (maximum), 33 W (typical)
Dimensions	395.5 mm × 22.5 mm × 225 mm (Height × Width × Depth)
Weight	0.752 kg

3.5.2 E1/T1 TDM Interface Cards

Function

E1/T1 TDM interface cards supports CES. The ZX A10 C300/C350/C320 supports the following E1/T1 TDM interface cards:

- CTBB: 32-channel E1 balanced TDM interface card
- CTTB: 32-channel T1 balanced TDM interface card
- CTUB: 32-channel E1 unbalanced TDM interface card

The E1 interface card CTUB supports TDM service over Ethernet.

Panel

Figure 3-37, Figure 3-38, and Figure 3-39 show the E1/T1 interface card panels.

Figure 3-37 CTBB Panel



Figure 3-38 CTTB Panel



Figure 3-39 CTUB Panel



Indicators

Table 3-40 describes the indicators of the E1/T1 interface cards.

Table 3-40 Indicator Description for E1/T1 interface cards

Indicator	Status	Description
RUN	OFF	The card is not powered ON.
	Green LED flashes slowly (1 Hz).	The card works properly (INSERVICE).
	Green LED flashes quickly (2 Hz).	<ul style="list-style-type: none"> ● The card is in configuration process. ● The card is in BOOT writing process. Do Not pull out the card.
	Green LED is ON.	<ul style="list-style-type: none"> ● The card is in version starting process. ● The card is in BOOTROM program. ● The card is in PLD upgrading process.
	Red LED is ON.	The card is seriously faulty, such as hardware fault.

Indicator	Status	Description
	Yellow LED flashes slowly (1 Hz).	The card type is inconsistent with configuration (TYPEMISMATCH).
ALM	OFF	Tributary is not configured on NM.
	Green LED is ON.	Tributary is proper.
	Red LED is ON.	High order alarm occurs on service line to 2M card.
	Yellow LED is ON.	The configured tributary E1 line alarm occurs.

Interfaces

The E1/T1 interface cards provide 32-channel E1/T1. Each E1 channel has four pins. The upper two pins are used for receiving and the lower two pins are used for sending.

Button

The RST button is used for resetting card.

Principle Diagram

Figure 3-40 shows the principle diagram of the E1/T1 interface cards.

Figure 3-40 Principle Diagram of E1/T1 interface cards

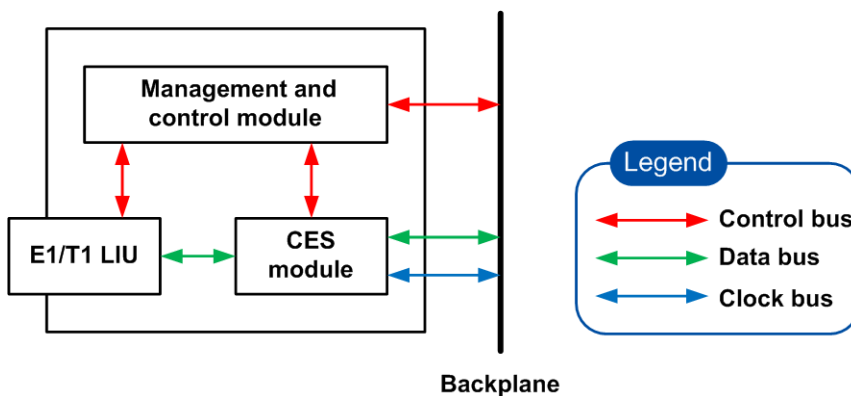

Table 3-41 describes the module functions of the E1/T1 interface cards.

Table 3-41 Module Functions of E1/T1 interface cards

Module	Function
Management and control module	Implements configuration, control, and management for each module in the card.
CES processing module	Downstream: extracts and recovers clock from LIU, composes CES packets using LIU data and transmits CES packets using LIU clock. Upstream: extracts and restores clock from CES packets, retrieves data from received CES packets and transmits data to LIU using the clock in CES packets.

Module	Function
E1/T1 line interface unit	Implements E1/T1 line CODEC, extracts and restores clock from the E1/T1 lines.

Technical Specifications

Table 3-42 lists technical specifications of the E1/T1 interface cards.

Table 3-42 Technical Specifications of E1/T1 interface cards

Item	Specification
Power consumption	CTBB/CTTB: 22 W (static/typical), 24 W (maximum) CTUB: 14 W (static/typical), 16 W (maximum)
Dimensions	395.5 mm × 22.5 mm × 225 mm (Height × Width × Depth)
Weight	CTBB/CTTB: 0.713 kg CTUB: 0.680 kg

3.6 Common Interface Cards

Function

The common interface card CIGG and CICK provide monitoring interfaces regarding environmental parameters, such as temperature, humidity, liquid, entrance control, and smog, as well as BITS clock and 1PPS+TOD time input and output interfaces. CIGG/CICK also provides input/output ports, such as network port, serial port, and trunk nodes. These ports are used to monitor external devices.

Panel

Figure 3-41 and Figure 3-42 show the common interface card panels.

Figure 3-41 CIGG Panel



Figure 3-42 CICK Panel



Indicators

Table 3-43 describes the indicators of the common interface cards.

Table 3-43 Indicator Description of Common Interface Cards

Indicator	Status	Description
RUN	Green LED flashes.	The card is working properly.
	Red LED is ON.	Card hardware failure
ETH	Green LED is ON.	The interface connection is proper, but no data is sending or receiving.
	Green LED flashes.	The interface is sending or receiving data.

Interfaces

Table 3-44 describes the interfaces of the common interface cards.

Table 3-44 Interface Description of Common Interface Cards

Interface	Description
CLKI1	The first BITS clock input interface, 75 Ω
CLKI2	The second BITS clock input interface, 75 Ω
CLKO/1PPSO	BITS/1PPS+TOD clock output interface, 75 Ω
CLKI1/TIMI1	The first BITS/1PPS+TOD clock input interface, 120 Ω
CLKI2/TIMI2	The second BITS/1PPS+TOD clock input interface, 120 Ω
CLKO/TIMO	BITS clock output interface, 120 Ω
ETH1	Out-of-band maintenance network interface
ETH2	Out-of-band maintenance network interface
ETH	Out-of-band maintenance network interface
COM	Public serial port
232/485	Reserved maintenance serial port
TEM	Temperature sensor interface
HUM	Humid sensor interface
SMO	Smog sensor interface
LIQ	Liquid sensor interface
DOR	Entrance control sensor interface
DIN	Digit input interface, four channels
DOT	Digit input interface, four channels

Principle Diagram

Figure 3-43 shows the principle diagram of the common interface cards.

Figure 3-43 Principle Diagram of Common Interface Cards

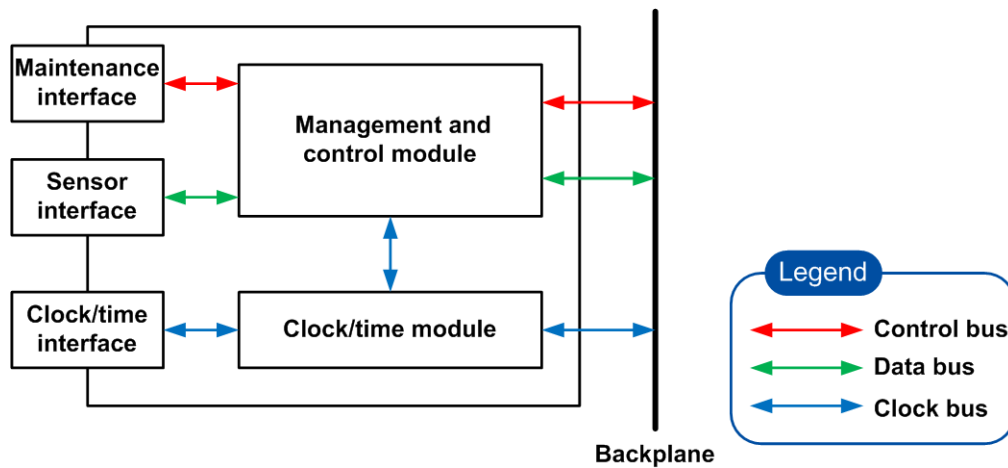

Table 3-45 describes the module functions of the common interface cards.

Table 3-45 Module Function of Common Interface Cards

Module	Function
Management and control module	Implements configuration, control, and management for each module in the card.
Interface module	Provides maintenance interfaces, sensor interfaces and clock input/output interfaces.
Clock module	Processes input and output clock on 75 Ω/120 Ω interfaces.

Technical Specifications

Table 3-46 lists technical specifications of the common interface cards.

Table 3-46 Technical Specifications of Common Interface Cards

Item	Specification
Power consumption	5 W
Dimensions	395.5 mm × 22.5 mm × 225 mm (Height × Width × Depth)
Weight	CICG: 0.719 kg CICK: 0.750 kg

3.7 Power Cards

Function

The ZXA10 C300/C350 power cards use -48 V DC power and provide power supply to each card. The system supports two power cards. When the input voltage of two power supplies is equal, the two power cards work in load-balance mode.

The ZXA10 C300/C350 supports two types of power cards: PRWG and PRWH.

- PRWG supports the maximum current of 30 A.
- PRWH supports the maximum current of 40 A.

The ZXA10 C320 power card PRAM uses 110 V or 220 V AC power and provides power supply to each card.

Panel

Figure 3-44, Figure 3-45 and Figure 3-46 show the power card panels.

Figure 3-44 PRWG Panel



Figure 3-45 PRWH Panel



Figure 3-46 PRAM Panel



Indicators

Table 3-47 describes the indicators of the power cards.

Table 3-47 Power Card Indicator Description

Indicator	Status	Description
RUN	Green LED is ON.	-48 V power input is available.
	Off	-48 V power input is unavailable.
PWR	Green LED is ON.	The power card works properly.
	Off	The power card is abnormal and fails to provide power supply to the system.

Indicator	Status	Description
BATTERY	Green LED is on.	The battery works properly.
	Green LED flashes quickly.	The battery is discharging, or the battery is reversely connected.
	Off	The battery is not available.

Interfaces

Table 3-48 describes the interfaces of the power cards.

Table 3-48 Power Card Interface Description

Interface	Description
PWR	Power interface
COM/TST1	Debug interface/reserved test interface
TST2	Reserved test interface
AC power interface (100-240V AC 50/60HZ)	Connects to 110 V/220 V AC power.
Battery interface (BAT+ BAT-)	Connects to a storage battery. BAT- connects to the negative of the battery. BAT+ connects to the positive of the battery.
TEMP SENSOR	Connects to a temperature sensor, for battery temperature compensation. Without a temperature sensor, the default temperature is set to 25 °C and the floating charge voltage is 53.5 V.

Switch

The **ON/OFF** switch is used to switch on/off the power.

Principle Diagram

Figure 3-47 shows the principle diagram of the PRWG/PRWH cards.

Figure 3-47 PRWG/PRWH Power Card Principle Diagram

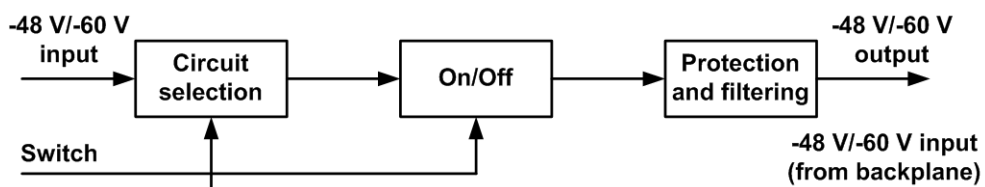

Figure 3-48 shows the principle diagram of the PRAM card.

Figure 3-48 PRAM Principle Diagram

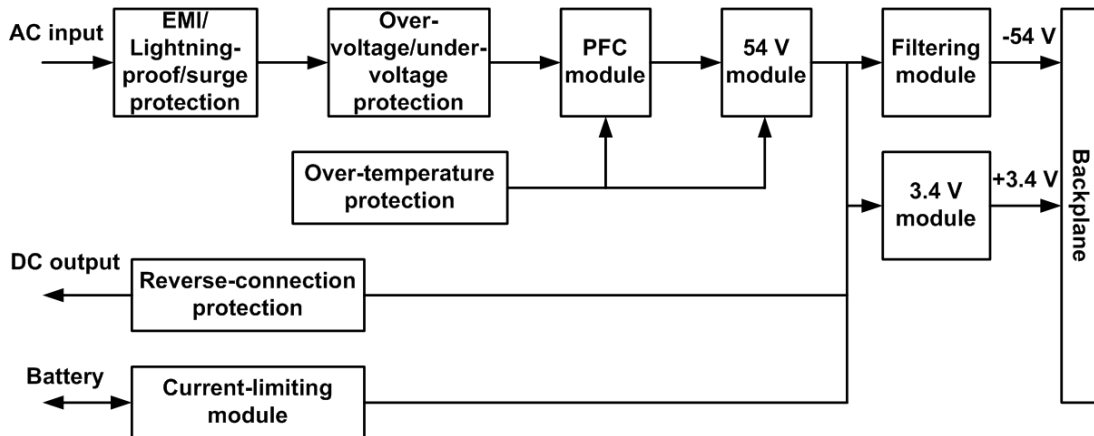

Table 3-49 describes functions of each module of the PRAM card.

Table 3-49 PRAM Module Functions

Module	Function
EMI/lightning-proof/surge protection	Implements the power input EMI (Electromagnetic Interference) filter, lightning-proof, and surge protection.
Over-voltage/under-voltage protection	Implements the power input over-voltage/under-voltage protection.
PFC module	Implements PFC (Power Factor Correction) function.
54 V module	Implements the conversion from AC voltage to 54 V DC voltage.
Over-temperature protection	Implements over-temperature protection, protecting the card from high temperature.
3.4 V module	Implements 3.4 V DC power output.
Current-limiting module	Implements the charge management and power-off management.

Technical Specifications

Table 3-50 lists technical specifications of the power cards.

Table 3-50 PRWG Technical Specifications

Item	Specification
Power consumption	PRWG/PRWH: 5 W PRAM: 13.2 W
Dimensions	PRWG/PRWH: 197.75 mm × 25 mm × 225 mm (Height × Width × Depth) PRAM: 200.25 mm × 37 mm × 225 mm (Height × Width × Depth)
Weight	PRWG/PRWH: 0.360 kg PRAM: 1.346 kg

3.8 Backplanes

Function

The backplane implements the electrical connection between ZXA10 C300/C350/C320 cards. The ZXA10 C300/C350/C320 supports the following backplanes:

- The 21-inch backplane MWEA or MWEA/R is used with the ZXA10 C300 ETSI 21-inch shelf.
- The 19-inch backplane MWIA or MWIA/R is used with the ZXA10 C300 IECI 19-inch shelf.
- The 19-inch backplane MWRV is used with the ZXA10 C350 shelf.
- The MWMT backplane is used with the ZXA10 C320 shelf.

Panel

Figure 3-49, Figure 3-50, Figure 3-51, and Figure 3-52 show the backplane panels.

Figure 3-49 21-Inch Backplane Panel

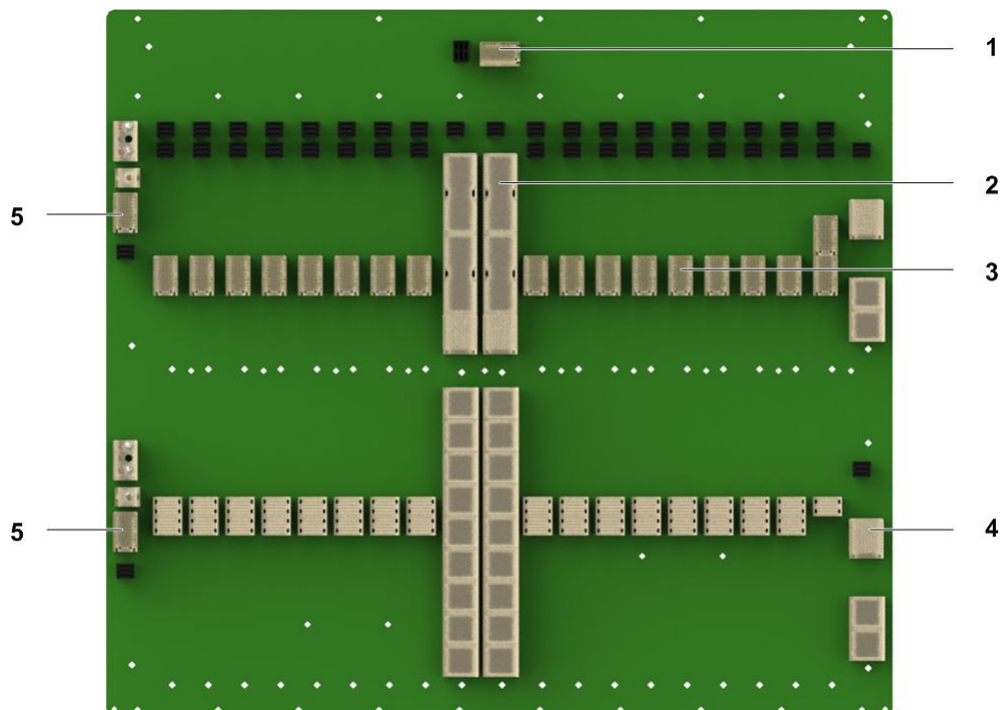

- | | |
|---|---------------------------|
| 1. Fan box interface | 3. Service card interface |
| 2. Switching and control card interface | 4. Uplink card interface |
| 5. Power card interface | 5. Power card interface |

Figure 3-50 19-Inch Backplane Panel

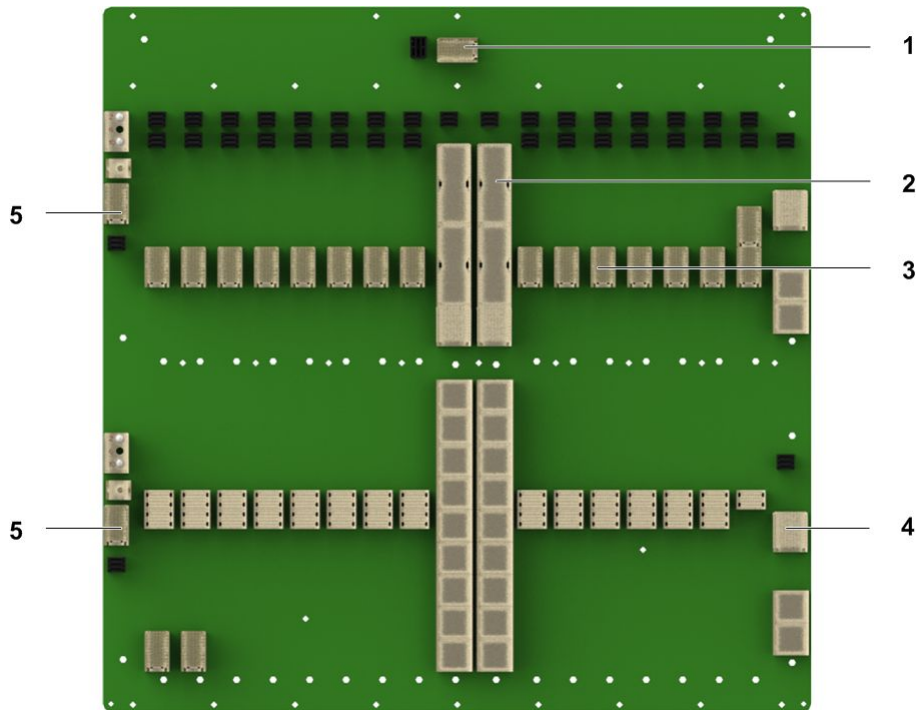

- | | |
|---|---------------------------|
| 1. Fan box interface | 3. Service card interface |
| 2. Switching and control card interface | 4. Uplink card interface |
| 5. Power card interface | 5. Power card interface |

Figure 3-51 MWRV Backplane Panel

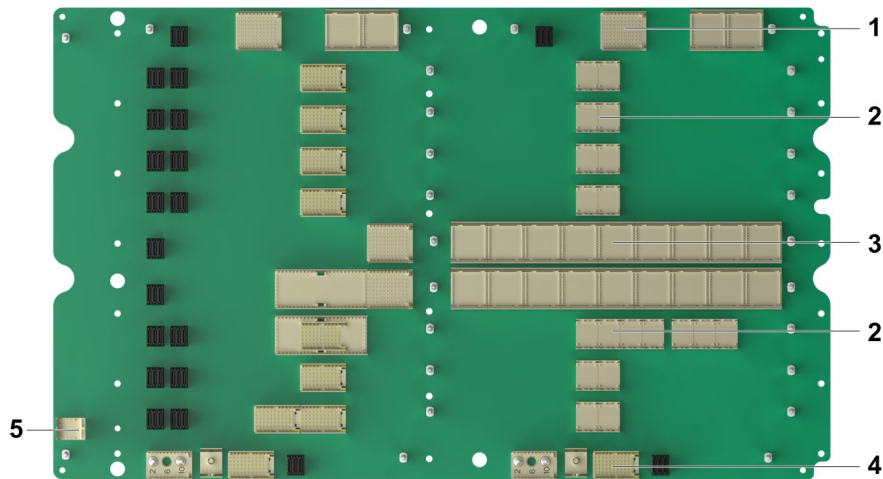

- | | | |
|---------------------------|---|-------------------------|
| 1. Uplink card interface | 3. Switching and control card interface | 4. Power card interface |
| 2. Service card interface | 5. Fan box interface | |

Figure 3-52 MWMT Backplane Panel

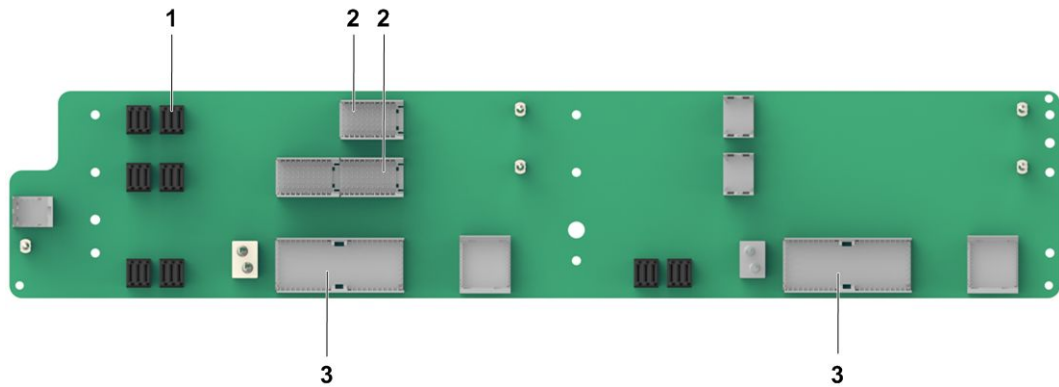

- 1. Fan box interface
- 2. Service card interface
- 3. Switching and control card interface

Interfaces

The backplane provides the following interfaces:

- Interfaces for switching and control cards, interface cards, and uplink cards
- Power card interface: -48 V, 48 V GND, 3.3 V, and GND
- Fan box interface: -48 V, -48 V GND, and fan detection/control

Technical Specifications

Table 3-51 lists technical specifications of the backplanes.

Table 3-51 Backplane Technical Specifications

Item	Specification
Dimensions	MWEA/MWEA/R: 440 mm × 481 mm (Height × Width) MWIA/MWIA/ : 440 mm × 440 mm (Height × Width) MWRV: 422.50 mm × 256 mm (Height × Width) MWMT: 81 mm × 411 mm (Height × Width)
Weight	MWEA/MWEA/R: 2.570 kg MWIA/MWIA/R: 2.350 kg MWRV: 1.450 kg MWMT: 0.395 kg

3.9 Fan Boxes

Function

The ZXA10 C300/C350/C320 uses a fan box for heat dissipation. The fan box consists of a fan control card (FCWB/FCWD/FAWR/F2U) and several fans.

- FCWB supports the single-line fan box for ZXA10 C300, which contains 3 or 4 fans.
- FCWD supports the dual-line fan box for ZXA10 C300, which contains 10 fans.

- FCWR supports the fan box for ZXA10 C350, which contains 6 fans.
- F2U supports the fan box for ZXA10 C320, which contains 2 fans.

The fan control card supports the following functions:

- Controls the rotating speed of fans to cool the system in accordance with the requirements for the working temperature.
- Indicates the operating status of fans.
- Controls the rotating speed of fans in accordance with the commands received from a NMS.
- Reports the status of each fan to the NMS.

Panel

Figure 3-53 shows the ZXA10 C300 fan box panel.

Figure 3-53 Panel of the ZXA10 C300 Fan Box

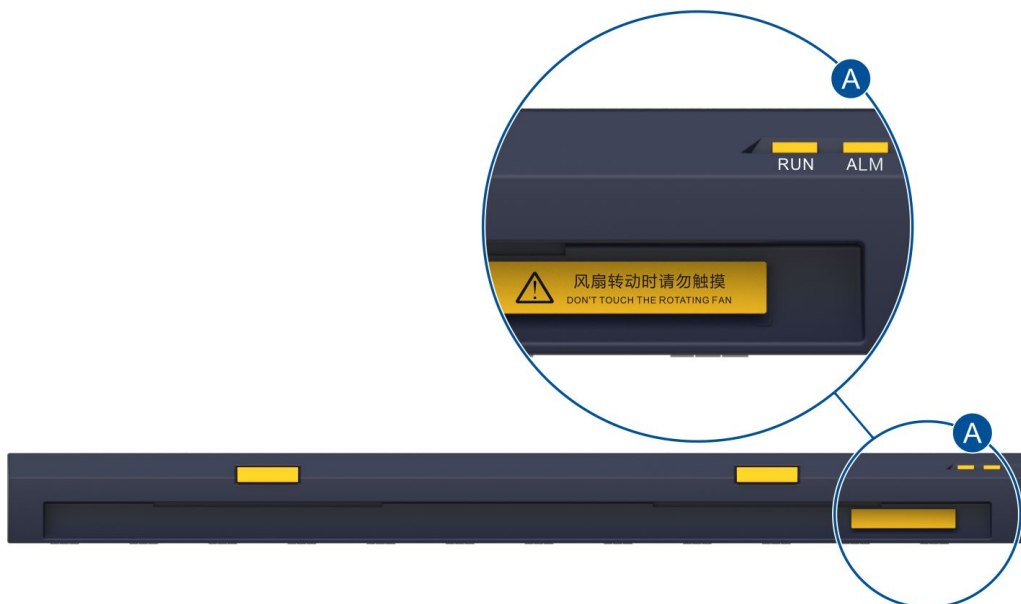

Figure 3-54 shows the ZXA10 C350 fan box panel.

Figure 3-54 Panel of the ZXA10 C350 Fan Box



Figure 3-55 shows the ZXA10 C320 fan box panel.

Figure 3-55 Panel of the ZXA10 C320 Fan Box



Indicators

Table 3-52 describes the indicators of the ZXA10 C300/C350/C320 fan box.

Table 3-52 ZXA10 C300/C350/C320 Fan Box Indicator Description

Indicator	Status	Description
RUN	Green LED is ON.	Power supply of the fan box is proper.
	OFF	The fan box is not powered on.
ALM	Red LED is ON.	At least one fan is faulty. Check the fan.
	OFF	Fans work properly.

Technical Specifications

Table 3-53 lists technical specifications of fan boxes.

Table 3-53 Fan Boxes Technical Specifications

Item	Specification
Power consumption	FAN-19/21 (FCWB): 9 W (static), 80 W (maximum), 35 W (typical) FAN-19/21 (FCWD): 11 W (static), 180 W (maximum), 75 W (typical) C320 fan box: 4 W (static), 20 W (maximum), 15 W (typical) C350 fan box: 38 W (maximum)
Dimensions (Height × Width × Depth)	FAN-19 (FCWB): 43.6 mm × 437 mm × 258.1 mm FAN-19 (FCWD): 43.6 mm × 437 mm × 258.7 mm FAN-21 (FCWB): 43.6 mm × 490.5 mm × 258.1 mm FAN-21 (FCWD): 43.6 mm × 490.5 mm × 258.7 mm C350 fan box: 257.3 mm × 37.3 mm × 235.2 mm C320 fan box: 84.3 mm × 35.8 mm × 247.9 mm
Weight	FAN-19 (FCWB): 2.420 kg FAN-19 (FCWD): 3.100 kg FAN-21 (FCWB): 2.520 kg FAN-21 (FCWD): 3.240 kg C350 fan box: 1.325 kg C320 fan box: 0.425 kg

Chapter 4

Cables

Table 4-1 lists the cables used by the ZXA10 C300/C350/C320.

Table 4-1 ZXA10 C300/C350/C320 Cables

Cable	Description
External power cables	Connect -48 V/-60 V power from the equipment room to the PDU.
Shelf power cable	Connects -48 V/-60 V DC power from the PDU to the power card.
E1 balanced cable	Connects E1/T1 interface on the CTBB/CTTB card.
E1 unbalanced cable	Connects E1 interface on the CTUB card.
Monitoring cables	Connect to the common interface card.
Ethernet cable	Connects to an Ethernet electrical interface.
Serial port cable	Connects the serial port of a maintenance computer to the CLI interface on the switching and control card.
Fiber pigtail	Connects optical fibers to an Ethernet optical interface or PON interface.

Table of Contents

External Power Cable.....	4-1
Shelf Power Cable.....	4-2
E1 Balanced Cable.....	4-3
E1 Unbalanced Cable	4-5
Serial Port Cable	4-7
Monitoring Cables	4-8
Ethernet Cable	4-10
Fiber Pigtail	4-11

4.1 External Power Cable

Appearance

Figure 4-1 and Figure 4-2 show the appearance of the external power cables.

Figure 4-1 -48 V/-60 V Power Cable Appearance



Figure 4-2 –48 V RTN/–60 V RTN Power Cable Appearance



Connection

Table 4-2 describes the external power cable connection.

Table 4-2 External Power Cable Connection

Cable	End A Connection	End B Connection
–48 V/–60 V power cable	Equipment room –48 V/–60 V output end	PDU –48 V/–60 V input end
–48 V RTN/–60 V RTN power cable	Equipment room –48 V/–60 V RTN output end	PDU –48 V/–60 V RTN input end

4.2 Shelf Power Cable

Appearance

Figure 4-3 shows the shelf power cable appearance.

Figure 4-3 Power Cable Structure

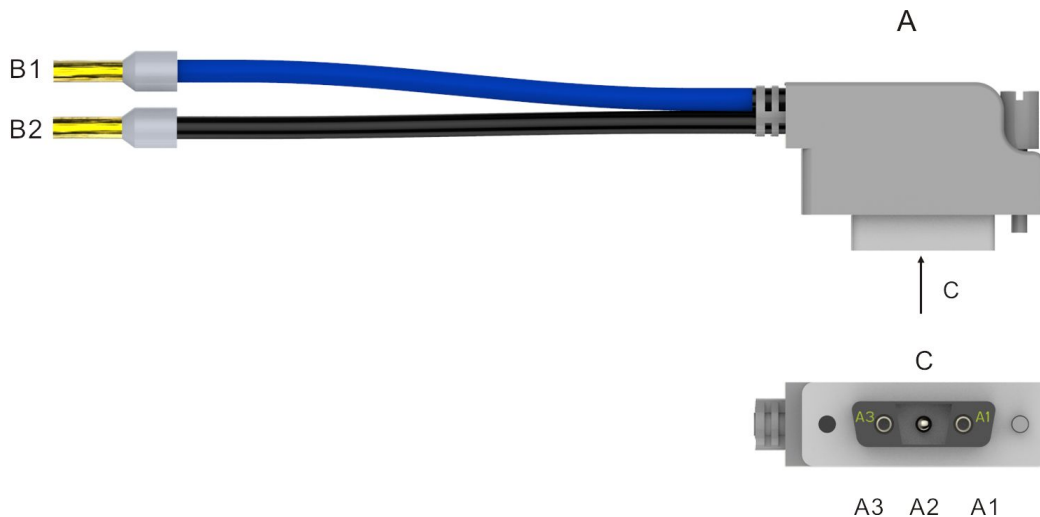

Connection

Table 4-3 describes the shelf power cable connection.

Table 4-3 Shelf Power Cable Connection

Cable	End A Connection	End B Connection
Shelf power cable	PWR interface on the power card	B1 connects to $-48\text{ V}/-60\text{ V}$ output end on the PDU . B2 connects to $-48\text{ V}/-60\text{ V}$ RTN output end on the PDU .

Pinouts

Table 4-4 describes the pinouts of the shelf power cable.

Table 4-4 Shelf Power Cable Pinout Description

End A	Cable Color	Signal	End B
A1	Black, with blue shell	$-48\text{ V}/-60\text{ V}$	B1
A3	Black	$-48\text{ V}/-60\text{ V}$ RTN	B2

4.3 E1 Balanced Cable

Appearance

Figure 4-4 shows the E1 balanced cable appearance.

Figure 4-4 E1 balanced Cable Appearance

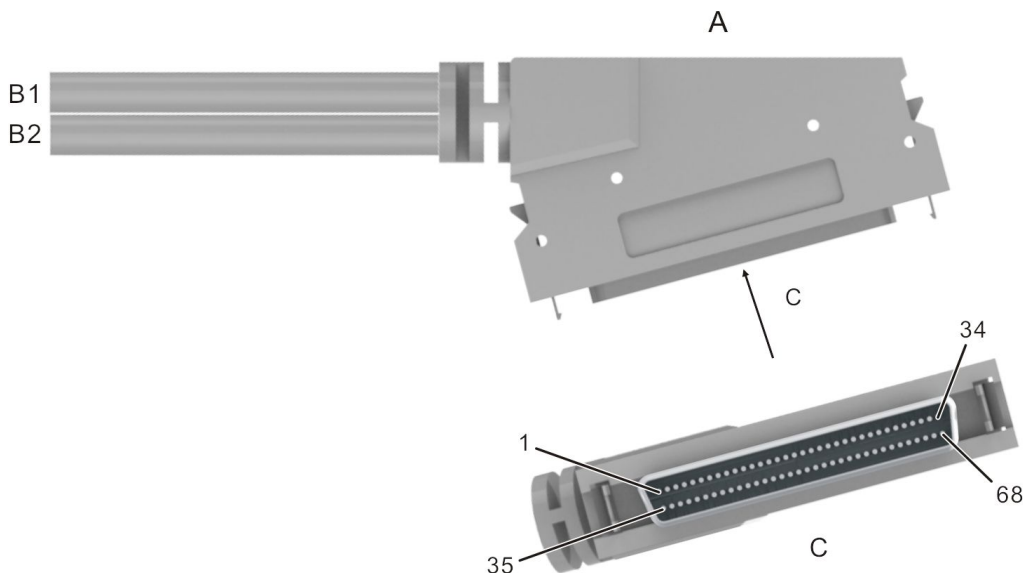

Connection

Table 4-5 describes the E1 balanced cable connection.

Table 4-5 E1 Balanced Cable Connection

Cable	End A Connection	End B Connection
E1 balanced cable	E1/T1 interface on the CTBB/CTTB card	DDF

Pinouts

Table 4-6 describes pinouts of E1 balanced cable.

Table 4-6 Pinouts Description of E1 balanced Cable

End A Pin	Cable Color B1	End A Pin	Cable Color B2
1	Blue (red 1)	17	Blue (red 1)
35	Blue (black 1)	51	Blue (black 1)
2	Pink (red 1)	18	Pink (red 1)
36	Pink (black 1)	52	Pink (black 1)
3	Green (red 1)	19	Green (red 1)
37	Green (black 1)	53	Green (black 1)
4	Orange (red 1)	20	Orange (red 1)
38	Orange (black 1)	54	Orange (black 1)
5	Grey (red 1)	21	Grey (red 1)
39	Grey (black 1)	55	Grey (black 1)
6	Blue (red 2)	22	Blue (red 2)
40	Blue (black 2)	56	Blue (black 2)
7	Pink (red 2)	23	Pink (red 2)
41	Pink (black 2)	57	Pink (black 2)
8	Green (red 2)	24	Green (red 2)
42	Green (black 2)	58	Green (black 2)
9	Orange (red 2)	25	Orange (red 2)
43	Orange (black 2)	59	Orange (black 2)
10	Grey (red 2)	26	Grey (red 2)
44	Grey (black 2)	60	Grey (black 2)
11	Blue (red 3)	27	Blue (red 3)
45	Blue (black 3)	61	Blue (black 3)
12	Pink (red 3)	28	Pink (red 3)
46	Pink (black 3)	62	Pink (black 3)
13	Green (red 3)	29	Green (red 3)

End A Pin	Cable Color B1	End A Pin	Cable Color B2
47	Green (black 3)	63	Green (black 3)
14	Orange (red 3)	30	Orange (red 3)
48	Orange (black 3)	64	Orange (black 3)
15	Grey (red 3)	31	Grey (red 3)
49	Grey (black 3)	65	Grey (black 3)
16	Blue (red 4)	32	Blue (red 4)
50	Blue (black 4)	66	Blue (black 4)

4.4 E1 Unbalanced Cable

Appearance

Figure 4-5 shows the E1 unbalanced cable appearance.

Figure 4-5 E1 Unbalanced Cable Appearance

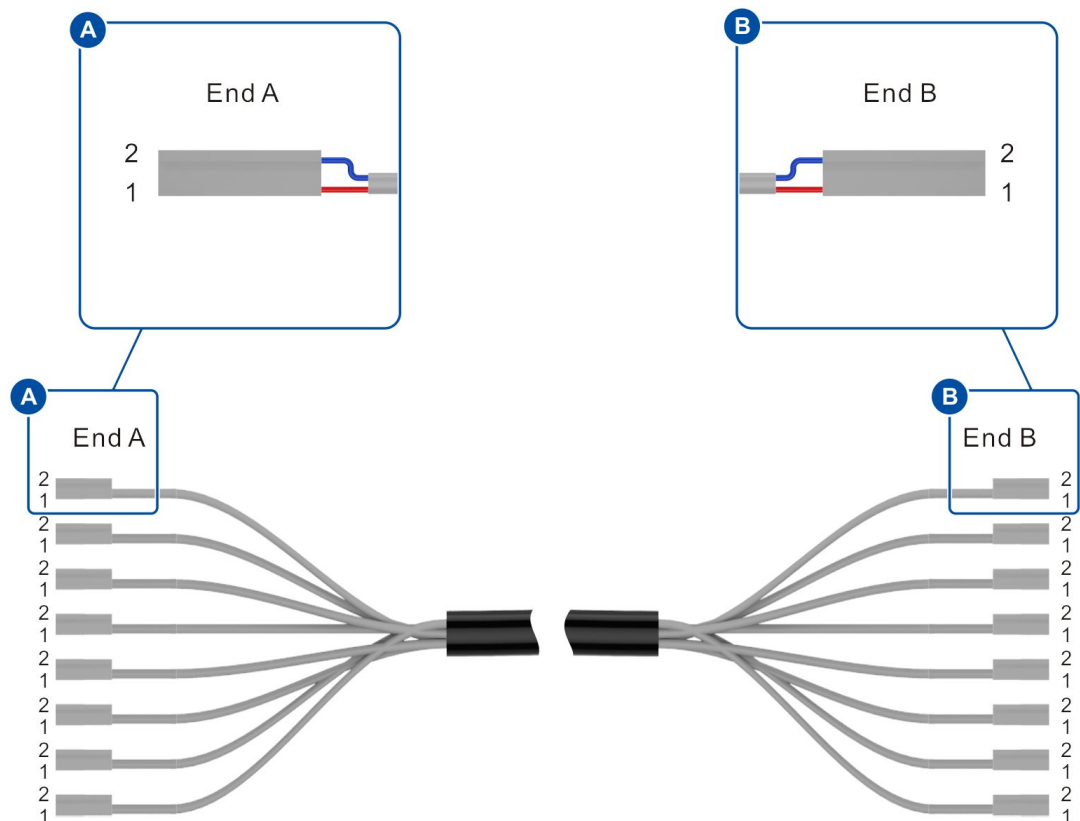

Connection

Table 4-7 describes the E1 unbalanced cable connection.

Table 4-7 E1 Unbalanced Cable Connection

Cable	End A Connection	End B Connection
E1 unbalanced cable	E1 interface on the CTUB card	DDF

Pinouts

Table 4-8 describes pinouts of E1 unbalanced cable .

Table 4-8 Pinouts of E1 Cable Unbalanced

End A Pin	E1 Signal	End B Pin	E1 Signal
A1	OUT16A	B1	GND
A2	IN16A	B2	IN16B
A3	OUT15A	B3	GND
A4	IN15A	B4	IN15B
A5	OUT14A	B5	GND
A6	IN14A	B6	IN14B
A7	OUT13A	B7	GND
A8	IN13A	B8	IN13B
A9	OUT12A	B9	GND
A10	IN12A	B10	IN12B
A11	OUT11A	B11	GND
A12	IN11A	B12	IN11B
A13	OUT10A	B13	GND
A14	IN10A	B14	IN10B
A15	OUT9A	B15	GND
A16	IN9A	B16	IN9B
A17	OUT8	B17	GND
A18	IN8A	B18	IN8B
A19	OUT7A	B19	GND
A20	IN7A	B20	IN7B
A21	OUT6A	B21	GND
A22	IN6A	B22	IN6B
A23	OUT5A	B23	GND
A24	IN5A	B24	IN5B
A25	OUT4A	B25	GND
A26	IN4A	B26	IN4B

End A Pin	E1 Signal	End B Pin	E1 Signal
A27	OUT3A	B27	GND
A28	IN3A	B28	IN3B
A29	OUT2A	B29	GND
A30	IN2A	B30	IN2B
A31	OUT1A	B31	GND
A32	IN1A	B32	IN1B

4.5 Serial Port Cable

Cable Structure

Figure 4-6 shows the serial port cable structure. End A is a RJ45 connector and End B is a DB9 connector.

Figure 4-6 Serial Port Cable Structure

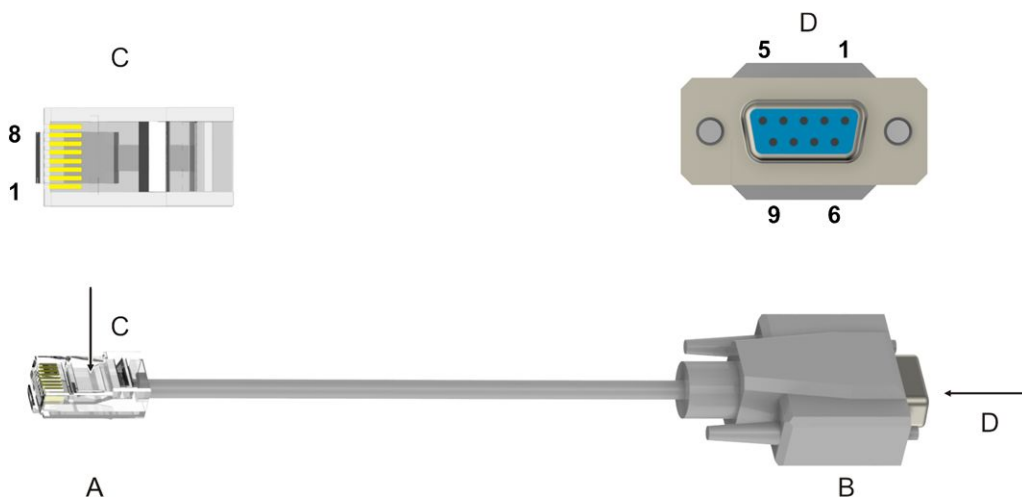

Pinouts

Table 4-9 lists pinouts of the serial port cable.

Table 4-9 Pinouts of the Serial Port Cable

End A	End B
3	3
4	5
5	5
6	2
Note: Other pins are not used.	

4.6 Monitoring Cables

Appearance

One end of the monitoring cable is a RJ-45 connector, and the other end is a sensor (except the smog monitoring cable, which is a 6-pin connector). [Figure 4-7](#) - [Figure 4-11](#) show the monitoring cable appearances.

Figure 4-7 Temperature Monitoring Cable

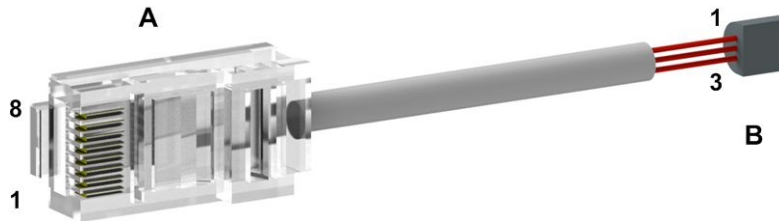

Figure 4-8 Humidity Monitoring Cable



Figure 4-9 Smog Monitoring Cable

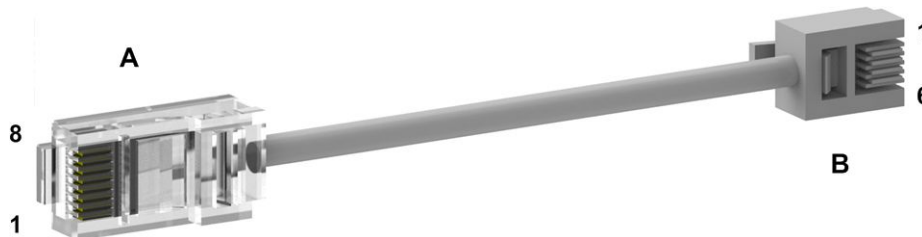

Figure 4-10 Liquid Monitoring Cable

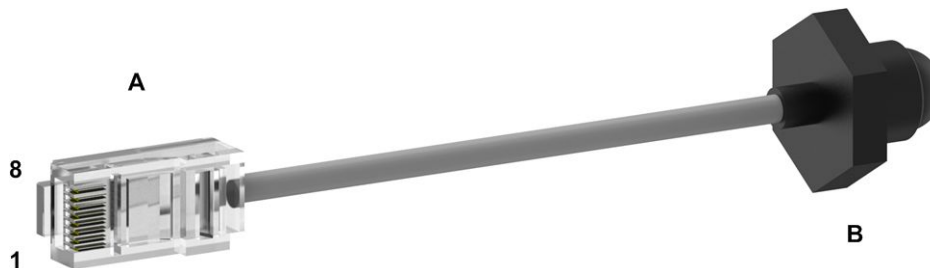
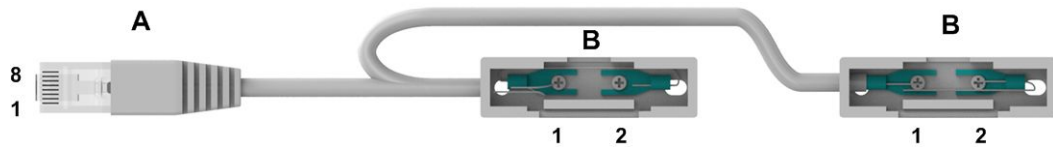

Figure 4-11 Security Monitoring Cable

Connection

Table 4-10 describes the monitoring cable connections.

Table 4-10 Monitoring Cable Connection Description

Cable Name	End A Connection	End B Connection
Temperature Monitoring Cable	Common interface card TEM interface	Middle of the cabinet
Humidity Monitoring Cable	Common interface card HUM interface	Middle of the cabinet
Smog Monitoring Cable	Common interface card SMO interface	Smog sensor on the upper part of the cabinet
Liquid Monitoring Cable	Common interface card LIQ interface	Lower part of the cabinet
Security Monitoring Cable	Common interface card DOR interface	Front/back doorcase of the cabinet

Pinouts

Table 4-11 describes the pinouts of the temperature monitoring cable.

Table 4-11 Pinouts Description of Temperature Monitoring Cable

End A Pin	Cable Color	End B Pin	Signal
7	White (white, blue)	3	+5 V
4	Blue (white, blue)	2	Temperature signal
1	Orange	1	GND

Table 4-12 describes the pinouts of the humidity monitoring cable.

Table 4-12 Pinouts Description of Humidity Monitoring Cable

End A Pin	Cable Color	End B Pin	Signal
7	White (white, blue)	3	+5 V
4	Blue (white, blue)	2	Humidity signal
1	Orange	1	GND

Table 4-13 describes the pinouts of the smog monitoring cable.

Table 4-13 Smog Monitoring Cable

End A Pin	Cable Color	End B Pin	Signal
8	White (white, blue)	5	+12 V
4	Blue (white, blue)	3	Smog signal
1	Orange	2	GND

Table 4-14 describes the pinouts of the liquid monitoring cable.

Table 4-14 Pinouts Description of Liquid Monitoring Cable

End A Pin	Cable Color	End B	Signal
1	White (white, blue)	Blue cable	GND
4	Blue (white, blue)	Green cable	Liquid signal
5	White (white, Orange)	Black cable	LED power
7	Orange (white, Orange)	Red cable	+5 V

Table 4-15 describes the pinouts of the security monitoring cable.

Table 4-15 Pinouts Description of Security Monitoring Cable

End A Pin	Cable Color	End B Pin	Signal
1	White	1	-
2	Blue	2	-

4.7 Ethernet Cable

Cable Structure

Ethernet cables are cat-5 cables with two ends of RJ45 connectors, see [Figure 4-12](#).

Figure 4-12 Ethernet Cable Structure

Pin Connections

Table 4-16 lists the pin connections of an Ethernet cable.

Table 4-16 Pin Connections of an Ethernet cable

End A	End B	Signal
RJ45_1	RJ45_3 (Crossover)	TPOP
	RJ45_1 (Straight-through)	
RJ45_2	RJ45_6 (Crossover)	TPOP
	RJ45_2 (Straight-through)	
RJ45_3	RJ45_1 (Crossover)	TPIP
	RJ45_3 (Straight-through)	
RJ45_6	RJ45_2 (Crossover)	TPIN
	RJ45_6 (Straight-through)	

**Note:**

The length of an Ethernet cable cannot be longer than 100 m.

4.8 Fiber Pigtail



Cable Description

A fiber pigtail is a single short fiber which connects the **PON** optical interface or Ethernet optical interface. A fiber pigtail has optical connectors at one end.

Connector Description

Table 4-17 describes the optical connectors.

Table 4-17 Optical Connector

Type	Description	Image	Interface
LC/PC	Lucent connector (for physical contact), with regular polish quality		Ethernet optical interface
SC/PC	Square optical connector (for physical contact), with regular polish quality		PON optical interface

This page intentionally left blank.

Glossary

1PPS

- 1 Pulse Per Second

AC

- Alternating Current

BITS

- Building Integrated Timing Supply

CES

- Circuit Emulation Service

CLI

- Command Line Interface

CODEC

- Code and Decode

CPU

- Central Processing Unit

DC

- Direct Current

DDF

- Digital Distribution Frame

EMI

- Electromagnetic Interference

EPON

- Ethernet Passive Optical Network

FE

- Fast Ethernet

GE

- Gigabit Ethernet

GND

- Ground

GPON

- Gigabit Passive Optical Network

LACP

- Link Aggregation Control Protocol

LED

- Light Emitting Diode

LIU

- Line Interface Unit

LOF

- Loss of Frame

LOS

- Loss of Signal

MAC

- Media Access Control

NM

- Network Management

NMS

- Network Management System

OAM

- Operation, Administration and Maintenance

ONU

- Optical Network Unit

P2P

- Point to Point

PDU

- Power Distribution Unit

PE

- Protective Earth

PFC

- Power Factor Correction

PLD

- Programmable Logic Device

PON

- Passive Optical Network

QoS

- Quality of Service

RS-232

- Recommended Standard 232

RTN

- Return

SD

- Secure Digital memory card

SDH

- Synchronous Digital Hierarchy

SLA

- Service Level Agreement

SONET

- Synchronous Optical Network

STM

- Synchronous Transport Module

STM-N

- Synchronous Transport Module, level N(N=1, 4, 16, 64)

TC

- Transparent Clock

TDM

- Time Division Multiplexing

TM

- Traffic Management

TOD

- Time of Day

VLAN

- Virtual Local Area Network

WDM

- Wavelength Division Multiplexing

XG-PON

- 10-Gigabit-Capable Passive Optical Network